

# ***Vi-PEC***

*versatile intelligent performance engine control*

## ***V44 & V88 Wiring and Installation Manual***

*vi-pec.com*

*Made in NZ*



# NOTICE

Due to frequent upgrades, Vi-PEC Tuning Software is not distributed with new Vi-PEC ECU's.

Vi-PEC Tuning Software is available for free download at the following web site:

[www.Vi-PEC.com](http://www.Vi-PEC.com)

Should internet download not be practical, a copy of the latest version of Vi-PEC Tuning Software on CD can be requested from your nearest Vi-PEC Dealer.

# CONTENTS

---

1 – INTRODUCTION.....	5
2 – CHOOSING A CONFIGURATION.....	8
2.1 – INJECTOR OUTPUTS.....	8
2.2 – IGNITION OUTPUTS.....	9
2.3 – AUXILIARY OUTPUTS.....	9
2.4 – ANALOG/TEMPERATURE INPUTS.....	11
2.6 – TRIGGER INPUTS.....	13
2.7 - SUMMARY.....	15
3 - COMPONENT INSTALLATION LOCATIONS.....	20
3.1 – ECU LOCATION.....	20
3.3 – MAP SENSOR LOCATION.....	21
4 – V44 HEADER PINOUT.....	23
5 – V88 HEADER PINOUT.....	24
6 – WIRING OF POWER AND GROUNDS.....	25
6.1 – POWER SUPPLIES.....	25
6.2 – +14V IN.....	25
6.3 – +14V AUX 9/10.....	26
6.5 – SENSOR GROUND.....	29
6.7 – +8V OUT.....	30
6.8 – ECU HOLD POWER WIRING.....	30
7 – INPUT SIGNAL WIRING.....	33
7.1 – TRIGGER INPUTS.....	33
7.2 – MAP SENSOR.....	37
7.3 – THROTTLE POSITION SENSOR.....	39
7.4 – ENGINE COOLANT TEMPERATURE (ECT).....	41
7.5 – INLET AIR TEMPERATURE.....	42
7.6 – NARROW BAND OXYGEN SENSOR.....	43
7.6.1 – LEAD TOLERANCE.....	44
7.6.2 - HEATING.....	44
7.6.3 - MOUNTING.....	44

7.8 – GP PRESSURE AND TEMP SENSING.....	47
7.9 – DIGITAL INPUT WIRING.....	47
7.9.1 – VEHICLE SPEED INPUT.....	48
7.9.2 – VVT CAM POSITION INPUT.....	48
8 – OUTPUT WIRING.....	50
8.1 – FUEL INJECTOR DRIVES.....	50
8.1.2 – LOW IMPEDANCE INJECTORS.....	51
8.1.3 – WIRING BALLAST RESISTORS.....	51
8.1.3 – SINGLE-POINT GROUP INJECTION.....	53
8.1.4 – MULTI-POINT GROUP INJECTION.....	53
8.1.5 – SEQUENTIAL INJECTION.....	54
8.1.6 – STAGED INJECTION.....	54
8.2.1 – IGNITER REQUIREMENTS.....	57
8.2.2 – COIL REQUIREMENTS.....	59
8.2.3 – IGNITION SUPPRESSION.....	60
8.2.4 – DISTRIBUTOR IGNITION.....	61
8.2.6 – MULTI-COIL: DIRECT SPARK.....	66
8.3 – IDLE SPEED CONTROL.....	67
8.3.1 – TWO TERMINAL ISC SOLENOID.....	68
8.3.3 – FOUR TERMINAL ISC STEPPER MOTOR.....	70
8.3.4 – SIX TERMINAL ISC STEPPER MOTOR.....	71
8.4 – TACHOMETER.....	72
8.5 – AUXILIARY OUTPUTS.....	72
8.6 – ELECTRONIC BOOST CONTROL.....	75
8.6.1 – RECOMMENDED BOOST CONTROL SOLENOID.....	76
8.6.3 – EXTERNAL WASTEGATES.....	79
8.6.4 – WIRING AND MOUNTING OF BCS.....	80
8.7 – SWITCHING THROUGH A RELAY.....	82
8.7.1 – FUEL PUMP RELAY.....	82
8.7.2 – ENGINE COOLANT FAN RELAY.....	83
8.7.3 – AIR CONDITIONING CLUTCH.....	83
8.7.4 – INTERCOOLER WATER SPRAY.....	83
8.8 – WATER OR NITROUS OXIDE INJECTION.....	83
8.9 – SWITCHING AN LED.....	84
8.10 – EMISSIONS CONTROL SOLENOIDS.....	84
8.11 – VVT CONTROL SOLENOIDS.....	84
8.12 – ELECTRONIC THROTTLE CONTROL.....	85
9 – PC TUNING.....	87

9.1 – INSTALLING USB DRIVERS.....	87
9.2 – INSTALLING Vi-PEC Tuning Software.....	87
9.2.1 – INSTALLING FROM THE WEB.....	88
9.2.2 – INSTALLING FROM A CD.....	88
9.3 – COMMUNICATING WITH YOUR ECU.....	89
10 – FIRST TIME SETUP.....	91
10.1 – PRE-START SETUP .....	91
10.1.1 – PRE-SETUP CHECKS.....	91
10.1.2 – CONNECTING TO Vi-PEC Tuning Software.....	91
10.2 – INITIAL CONFIGURATION.....	92
10.2.1 – CONFIGURATION AND FUELING SETUP.....	92
10.2.2 – IGNITION SETUP.....	94
10.2.3 – LIMITS SETUP.....	95
10.2.4 – AUXILIARY OUTPUT SETUP.....	95
10.2.5 – DIGITAL INPUT SETUP.....	96
10.2.6 – ANALOG INPUT SETUP.....	97
10.2.7 – TRIGGER SETUP.....	98
10.3 – TRIGGER CALIBRATION.....	99
10.4 – FIRST TIME STARTUP.....	100
10.5 – ESSENTIAL TUNING ADJUSTMENTS.....	102
10.5.1 – MAP SENSOR CALIBRATION.....	102
10.5.2 – INJECTOR VOLTAGE (DEAD TIME) CORRECTION.....	103

# 1 – INTRODUCTION

---

Thank you for purchasing your Vi-PEC Wire-In Engine Control Unit (ECU). Vi-PEC VX ECU's are an advanced, fully programmable microprocessor controlled Engine Management System.

The VX software platform boasts an impressive list of features giving a new level of user adjustment. This flexibility allows the tuner to have complete control over the engine management system. VX software employs high resolution fuel and ignition tables with configurable load and RPM centers. When coupled with up to five dimensional fuel and ignition mapping, barometric pressure compensation and intake air temperature correction this gives an unprecedented level of tuning accuracy. All VX ECU's are in field upgradeable, there is no need to return the unit for software updates.

All Vi-PEC VX Wire-In Engine Management Systems are designed with flexibility and ease of installation in mind. Vi-PEC Wire-In systems are designed to be wired to either existing wiring or preferably as a complete re-wire. In some cases adapter looms or header boards can be purchased to allow wiring of the VX ECU to factory ECU headers. Contact your nearest Vi-PEC dealer for more information on these.

Vi-PEC Engine Management Systems are designed with the final result in mind. Not only do they boast an impressive range of performance features, but are designed with a focus on safety, reliability and drive-ability. However, the ultimate success of your engine management upgrade is determined by how well the system is installed and tuned.

Installing and tuning any aftermarket engine management system is not to be taken lightly. VX ECU's give the tuner the control &

flexibility that only top after-market engine management systems in the world can provide. While every effort has been made to keep VX ECU's as user friendly as possible, it should be recognised that added features bring added complexity.

The complete setup of your ECU can be divided into two equally important tasks.

1. This manual covers the wiring and installation of your VX ECU. While it is not strictly essential that this work is performed by an automotive electrician, the knowledge and tools available to these professionals makes it highly recommended. Regardless of who does the installation, it is of utmost importance that clean and robust connections are made throughout the installation. A significant majority of after market engine management failures are due to poor wiring practices. Note that use of complex features such as Variable Valve Timing, Electronic Throttle Control and ECU Hold Power require advanced wiring practice.
2. Once the VX ECU has been installed it will need to be tuned using a laptop computer with Vi-PEC Tuning Software software. Information on the configuration and tuning of the VX ECU is detailed in the online help section of Vi-PEC Tuning Software. VX ECU's are shipped pre-loaded with a base configuration that should be close enough to get most engines running after a few application specific adjustments have been made. While hearing the engine running on the new ECU for the first time is always a satisfying feeling, it is important to realise that the job is not complete. The amount of tuning performed and the experience of the tuner are the two most important factors in determining how happy you will be with your engine management system.

Should any issues arise during installation, the following options exist for technical support:

1. Contact your nearest Vi-PEC dealer. A Vi-PEC dealer list is available on our website.
2. Vi-PEC website: [www.Vi-PEC.com](http://www.Vi-PEC.com)
3. Technical Support Email: [tech@Vi-PEC.com](mailto:tech@Vi-PEC.com)
4. Online Discussion Board: Available from the Vi-PEC website.

The majority of questions received by the technical support team are clearly answered in the manuals. To speed up your technical inquiry please consult the manuals to make sure that your question has not already been answered.

## 2 – CHOOSING A CONFIGURATION

---

As all VX inputs/outputs are configurable, the required connections will be highly dependent on the application. Read this section carefully to ensure the correct functions are chosen.

The first step in installing a VX ECU is to decide what function each of the configurable inputs and outputs will provide.

The VX ECU's have the following input / output pins:

IO	V44	V88
Injection Drives	4 x Saturated	8 x Peak and Hold
Ignition Drives	4	8
Auxiliary Outputs	8	10
Digital Inputs	3 or 4*	10
Analog Voltage Inputs	3 or 4* + Internal MAP	11
Temperature Inputs	4	2
Knock Sensor Inputs	2	2
Regulated Output	+8V and +5V	+8V and +5V
Trigger Inputs	2	2

\* V44 shares one header pin for DI4 and An Volt 2

### 2.1 – INJECTOR OUTPUTS

The V88 has eight independent current controlled (Peak and Hold) injector drives allowing sequential, sequential staged, group and group staged fuel injection. These injection drives are designed to be used with low or high impedance injectors without the use of ballast resistors. Unused Injection channels can be used for additional auxiliary outputs.

The V44 has four independent saturated injector drives allowing sequential, group and group staged fuel injection. These injection drives are designed to be used with high impedance injectors. Injector ballast resistors must be wired if low impedance injectors are to be used. Unused Injection channels can be used for additional auxiliary outputs.

VX Injection Specifications:

- Max Peak Current = 10 A
- Max Hold Current = 3 A
- Max Saturated Injection or Auxiliary Output Current = 5 A
- Open Collector (not flywheeled) in auxiliary output mode.

## 2.2 – IGNITION OUTPUTS

The V88 offers eight independent ignition drives which can be used in a wide range of configurations from a basic distributor setup through to more complex multi-coil arrangements. Unused ignition channels can be used for additional auxiliary outputs (simple switching functions only). All direct spark, wasted spark and distributed ignition configurations requiring up to eight channels are supported by the V88

The same as above applies for the V44 however the V44 has only four ignition outputs.

VX Ignition Specifications:

- Ignition Drive High 20mA @ 5V
- Ignition Drive Low 2A overcurrent protected
- Open Collector (not flywheeled) in auxiliary output mode.

## 2.3 – AUXILIARY OUTPUTS

VX Wire in ECU's have eight general purpose auxiliary outputs. Unused ignition and injection channels can also be used as

auxiliary outputs. Auxiliary outputs are general-purpose outputs that may be used to perform a wide range of functions. However, the following limitations apply:

- A Three Terminal ISC Solenoid must be wired to Aux 1 and Aux 2.
- An ISC Stepper Motor must be wired to Aux 5, Aux 6, Aux 7 and Aux 8.
- Variable Valve Timing (VVT) solenoids must be wired to Aux 1 to 4.
- Aux 5 to 8 can not be Pulse Width Modulated (PWM) above 300Hz. Note that PWM frequencies above 300 Hz may be required to drive a tachometer for a V8 above 4500 RPM.
- An electronic throttle motor must only be wired to Aux 9 (+) and Aux 10 (-).
- Spare Injection and Ignition channels when used as auxiliary outputs can only be used as Auxiliary Outputs.

Auxiliary outputs supply an earth to switch loads such as a solenoid, relay, bulb or LED. All auxiliary outputs may be used as a conditional switch that becomes activated at a certain value (e.g. Honda VTEC), or for more complex control operations such as idle speed control and electronic boost control.

Loads may be connected directly to the auxiliary output without using a relay provided they do not draw more than 2A of current. Essentially this means that a directly connected load should have a resistance exceeding 7  $\Omega$ . Refer to the section on wiring auxiliary outputs.

Some of the functions that may be performed by auxiliary outputs include:

- ✓ Fuel Pump Relay Switching (highly recommended for

safety reasons)

- ✓ Engine Coolant Fan Relay Switching
- ✓ Electronic boost control using a boost control solenoid (uses PWM)
- ✓ Variable valve timing solenoid (e.g. VTEC)
- ✓ Warning / Check Engine Light
- ✓ Purge Control
- ✓ EGR Control
- ✓ Any function requiring an output activated by temperature, manifold pressure (MAP), RPM, gear position, digital input state etc.
- ✓ Water Injection / nitrous oxide control (uses PWM)
- ✓ Intercooler Water Spray
- ✓ Air Conditioning Clutch / Fan
- ✓ General Purpose PWM
- ✓ Idle Speed Control solenoids or stepper motors
- ✓ Electronic Throttle Control

VX Auxiliary Output Specifications:

- 1.5 kOhm Internal Pullup Resister
- Auxiliary Drive Low 2A overcurrent protected
- Open Collector (**flywheeled**) in auxiliary output mode.
- Aux 5 to 8 High Side Drive (ISC Stepper Mode) 0.5 A.
- Aux 9 and 10 (V88 only) Push-Pull drive 4/4 A.

## 2.4 – ANALOG/TEMPERATURE INPUTS

VX ECU's have plentiful analog voltage and analog temperature channels. The difference between volt and temperature channels is temperature channels have an internal pullup resister.

All analog volt channels are created equal and can be wired to any type of analog input (there is no restrictions as to what must be wired to each channel)

Analog Volt Inputs may be configured to accept an analog signal between 0-5V. Applications include:

- ✓ Narrow-band O2 (0-1V output)
- ✓ Wide-band O2 (via external wide-band controller)
- ✓ 0-5V Voltage (eg Boost Adjust)
- ✓ Pressure (from 0-5V transducer)

Temperature channels are designed to be used only with PTC or NTC thermistor sensors. Almost all factory temperature sensors fit this category. Do not wire the output of a 0-5V temperature sensor (eg a pyro module) to these channels, instead use an Analog Voltage Input.

Analog Channel Specifications:

- Measurable Input Range 0-5V DC
- Input impedance 2.2 MOhm DC (4.7 kOhm AC).
- Maximim Input Voltage +/- 50 V
- Temperature Channel Pullup Resister 1 kOhm to 5V

## 2.5 – DIGITAL INPUTS

Digital Inputs are inputs that recognise either a high (+V) or low (GND) signal. Digital inputs are typically setup to monitor the position of manual switches or connected to sensors that output a signal of variable frequency.

The following Digital Input Limitations Apply:

- Only Digital Inputs 1 to 6 can be used for frequency input (eg speed).
- Only Digital Inputs 1 to 4 can be used for Variable Valve Timing (VVT) cam position input.

VX ECU's have up to 10 Digital Inputs that can be configured for sensors/ switches such as:

- ✓ Vehicle Speed Sensor
- ✓ Antilag Switch
- ✓ Clutch Switch (for launch control and flat shifting)
- ✓ High / Low Boost Switch
- ✓ Water Spray Switch
- ✓ Dual Fuel / Ignition Map Switch
- ✓ Nitrous Oxide Switch
- ✓ Anti-theft Switch
- ✓ AC Request Switch

Digital Inputs have a software selectable pullup resistor that can be enabled when measuring from ground switching devices (such as hall effect sensors).

Digital Input Specifications:

- Low Level Input < 1V
- High Level Input > 2 V
- Digital Input Pullup Resistor (if enabled) 4k7 Ohm to 12V
- Maximum input voltage +/- 50 V

## 2.6 – TRIGGER INPUTS

Trigger inputs are required from crank/cam angle sensor(s) (CAS) for the VX ECU to calculate the current engine speed and position.

VX ECU's use on board digital trigger decoding to determine engine position from the given signals. Setup of the trigger inputs is performed using Vi-PEC Tuning Software. Contact your nearest Vi-PEC dealer for advice on wiring and setup of trigger inputs if unsure.

Trigger 1 is used to determine crankshaft position. Trigger 2 is used to determine the engines position in the firing order. In all cases Trigger 1 will need to be used. In many cases Trigger 2 must also be used.

Engines with Variable Valve Timing may also require Digital Inputs be wired to cam shaft position sensors.

Refer to the Trigger Wiring section for more information about trigger requirements for different ignition/injection setups.

## 2.7 - SUMMARY

After reading this chapter you should be able to complete a list outlining the basic configuration that will be used. It is important to write such a list as you will need to set up each output in Vi-PEC Tuning Software later on. An example of such a list is shown below. A blank table to be filled out by the installer is given in the following Section.

Configuration: 6 Cylinder, direct spark, sequential injection, turbocharged, variable valve timing	
Trigger 1	Crank Angle Sensor
Trigger 2	Cam Angle Sensor
Analog Volt 1	MAP Sensor (Vi-PEC 2.5 Bar)
Analog Volt 2	Throttle Position (TPS)
Analog Volt 3	Aftermarket Wide-band O2 Controller
Analog Volt 4	Factory Narrow Band O2 (0-1V)
Analog Volt 5 to 8	N/C
Analog Temp Input 1	Engine Coolant Temperature
Analog Temp Input 2	Inlet Air Temperature
Analog Temp Input 3	Fuel Temperature
Analog Temp Input 4	N/C
+5V Out	TPS and MAP sensor power
+8V Out	Cam/Crank angle sensor power supply
Ignition 1	Igniter Channel 1 (Cylinder 1)
Ignition 2	Igniter Channel 2 (Cylinder 2)
Ignition 3	Igniter Channel 3 (Cylinder 3)
Ignition 4	Igniter Channel 4 (Cylinder 4)
Ignition 5	Igniter Channel 5 (Cylinder 5)
Ignition 6	Igniter Channel 6 (Cylinder 6)
Ignition 7	Fuel Pump Relay
Ignition 8	A/C Clutch Relay
Injection 1	Injector 1 (Cylinder 1)
Injection 2	Injector 2 (Cylinder 2)

Configuration: 6 Cylinder, direct spark, sequential injection, turbocharged, variable valve timing	
Injection 3	Injector 3 (Cylinder 3)
Injection 4	Injector 4 (Cylinder 4)
Injection 5	Injector 5 (Cylinder 5)
Injection 6	Injector 6 (Cylinder 6)
Injection 7	Fuel Pump Speed Control 1
Injection 8	Fuel Pump Speed Control 2
Auxiliary Output 1	Idle Speed Control Solenoid (Close)
Auxiliary Output 2	Idle Speed Control Solenoid (Open)
Auxiliary Output 3	Tachometer
Auxiliary Output 4	Variable Valve Timing Solenoid
Auxiliary Output 5	Intercooler Water Spray
Auxiliary Output 6	Shift Light
Auxiliary Output 7	A/C Fan Relay
Auxiliary Output 8	Boost Control Solenoid
Digital Input 1	Vehicle Speed
Digital Input 2	Variable Valve Timing Cam Position Sensor
Digital Input 3	A/C Request Switch
Digital Input 4	I/C Spray Switch
Digital Input 5	Start Position Switch
Digital Input 6	Power Steer Switch
Digital Inputs 7 to 10	N/C

### Example of usage of inputs and outputs

## 2.8 – INSTALLER I/O TABLE

Fill out the following table to assist in installation. It will come in useful when configuring inputs and outputs in Vi-PEC Tuning Software. Shaded areas indicate I/O only available on V88 ECU's.

Configuration: 6 Cylinder, direct spark, sequential injection, turbocharged		
Trigger 1	Crank Angle Sensor	Reluctor, Optical or Hall
Trigger 2		
Analog Temp Input 1		NTC thermistor Sensors Only
Analog Temp Input 2		
Analog Temp Input 3		
Analog Temp Input 4		
Analog Volt 1		0-5V Input from sensor or external controller
Analog Volt 2		
Analog Volt 3		
Analog Volt 4		
Analog Volt 5	(Internal MAP on V44)	
Analog Volt 6		
Analog Volt 7		
Analog Volt 8		
Analog Volt 9		
Analog Volt 10		
Analog Volt 11		
+5V Out	TPS and MAP sensor power	Power OUT
+8V Out		
Ignition 1		Wire Ign 1 to cyl 1, 2 to 2, 3to 3 etc...  Use spare Ignition channels for switching type Auxiliary Outputs
Ignition 2		
Ignition 3		
Ignition 4		
Ignition 5		
Ignition 6		
Ignition 7		

Configuration: 6 Cylinder, direct spark, sequential injection, turbocharged		
Ignition 8		
Injection 1		Wire Inj 1 to cyl 1, 2 to 2, 3to 3 etc...  Use spare Injection channels for switching type Auxiliary Outputs
Injection 2		
Injection 3		
Injection 4		
Injection 5		
Injection 6		
Injection 7		
Injection 8		
Auxiliary Output 1		High Freq PWM or VVT Control Three Wire ISC Solenoid must be wired to Aux1 and Aux2.
Auxiliary Output 2		
Auxiliary Output 3		
Auxiliary Output 4		
Auxiliary Output 5		PWM < 300 Hz or general switching functions.  ISC Stepper
Auxiliary Output 6		
Auxiliary Output 7		
Auxiliary Output 8		
Auxiliary Output 9	(Ethrottle Motor +)	E Throttle Motor or GP Output
Auxiliary Output 10	(Ethrottle Motor -)	
Knock 1		Knock Sensors Only
Knock 2		
Digital Input 1		Frequency Input, Switch Input or VVT Position
Digital Input 2		
Digital Input 3		
Digital Input 4		
Digital Input 5		Frequency Input or Switch Input
Digital Input 6		
Digital Input 7		Switch Input Only
Digital Input 8		
Digital Input 9		
Digital Input 10		

### Usage of inputs and outputs

# 3 - COMPONENT INSTALLATION LOCATIONS

---

The VX Engine Management System and associated components may be installed in a variety of locations but it is important to choose component locations in accordance with the following guidelines.

## 3.1 – ECU LOCATION

1. The VX ECU requires environmental protection for both physical and electrical factors that may affect its performance. Normally this requires the device to be fitted inside the vehicle cabin. This position avoids the high temperatures associated with the engine bay and reduces the chances of the ECU getting wet. This position also offers some physical separation between the ECU and ignition components that may cause interference.
2. The main exception to this rule is where the engine is somewhat distant from the driving position, such as a boat. In these cases the ECU should be mounted in close proximity to the engine but NOT directly on, or next to, the engine (e.g. mounted just outside the engine compartment). The idea here is to minimise the length of wiring between the engine and the ECU while maintaining some physical distance to prevent heat and interference. It is preferable to have short main wiring and a longer tuning cable.
3. If water immersion or spray is likely (particularly for marine applications), additional protection may be necessary. A sealed plastic container may be employed here.
4. Allow sufficient space at both ends of ECU for the main wiring harness and tuning cables to be connected.

5. A mounting bracket is provided. Install the bracket on a flat surface and clip the ECU into this bracket firmly. Use only the mounting bracket provided and DO NOT drill holes in the case, as this will probably cause internal damage.

## 3.2 – IGNITION COMPONENT PLACEMENT

All components of the ignition system have the potential to radiate large amounts of interference (electromagnetic radiation) that can wreak havoc on sensitive electronic devices. Therefore it is essential that the ignition components are carefully placed and that full suppression techniques are used. See the ignition wiring section for further details.

**IMPORTANT** - Never mount the igniter onto or next to the ECU

Always mount igniter(s) in the engine bay as close to the ignition coil(s) as possible. This helps to minimize the length of high current wiring between the igniter(s) and coil(s). Avoid areas of high temperature such as exhausts, turbochargers and radiators since the igniter itself will generate heat at high power. If vibration levels will be excessively high, some form of soft or rubber mounting is advisable to prevent component and wiring fatigue. Preferably igniters should be mounted on the chassis rather than the engine to reduce vibration.

## 3.3 – MAP SENSOR LOCATION

A Manifold Absolute Pressure (MAP) sensor is required for almost all applications. V44 ECU's have an internal MAP sensor but can also be wired using an external MAP sensor. V88 ECU's require the installation of an external MAP sensor. The MAP Sensor should be installed in a location near the engine, but

away from excessive heat, vibration and moisture. It is not recommended to mount the MAP sensor directly on the engine. Refer to Input Wiring section for more information on plumbing and wiring the MAP sensor.

Ideally the MAP sensor should be mounted higher than the inlet manifold so that moisture will not condense in the MAP sensor hose.

# 4 – V44 HEADER PINOUT

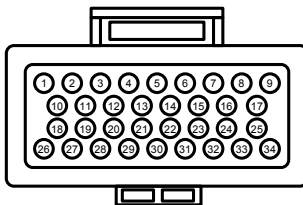
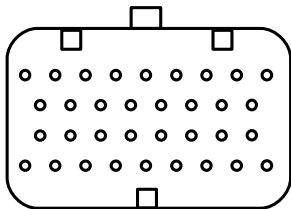

A

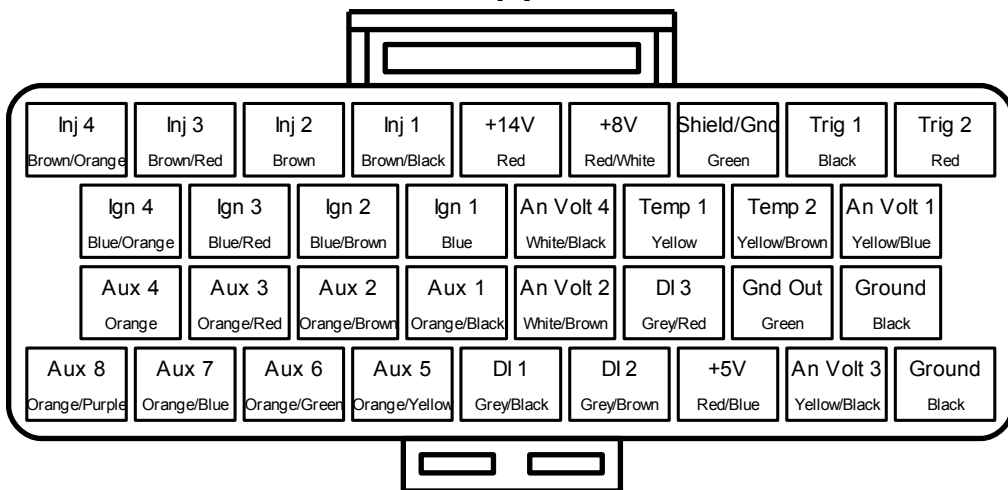

# 5 – V88 HEADER PINOUT

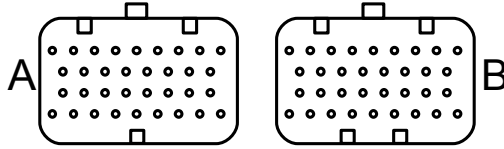

A

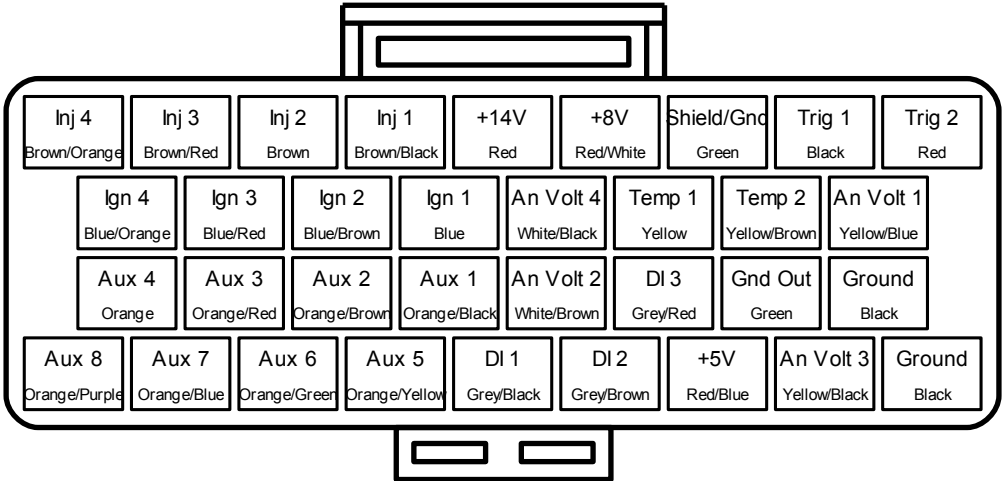

B

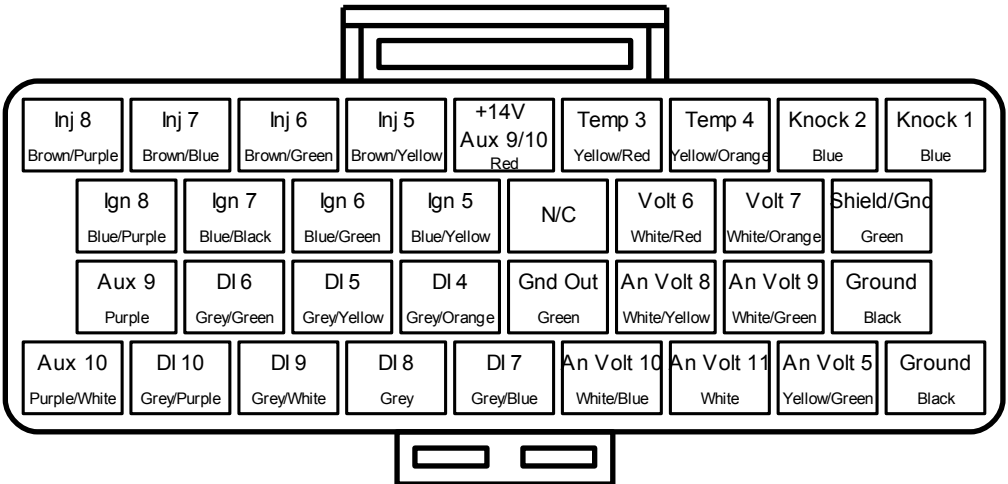

# 6 – WIRING OF POWER AND GROUNDS

---

Correct wiring of the power supplies is a very important part of the installation process. The following sections describe wiring of power supplies to the ECU and also power supplies from the ECU.

## 6.1 – POWER SUPPLIES

Figure 6.1 (next page) shows the recommended wiring arrangement for the power supplies. The following key points are worthy of noting:

1. The switch labelled 'ignition switch' is usually the key. The wire that is used to turn on the main relay should be energised when the key is in the 'ON' position. Do not use a source that provides power when the key is in the ACC position as these are typically disconnect while the starter motor is being cranked.
2. Each relay uses it's own fuse. Ideally these should be located as close to the battery as possible to minimise the length of un-fused wiring.
3. When the main relay is turned off all other relays will turn off. However, the high current supplied by the other relays is NOT drawn through the main relay.

## 6.2 – +14V IN

V44 ECU's have one red wire that supplies power to the ECU's internal supplies. V88 ECU's have two red power wires. The power wire in connector A is used to power the ECU's internal supplies. The red +14V Aux 9/10 power wire in connector B is

used to power the Aux 9 and Aux 10 drivers (Refer to section 6.3). As shown in Figure 6.1 the for non electronic throttle control applications the red wires should be connected to a relay that provides power when the key is in the 'ON' position. BOTH +12V In wires must be connected at all times.

Although the ECU does not draw a large amount of current, the voltage applied to the '+14V In' wire must remain above 7 Volts at all times. This is especially important while the starter motor is being cranked. A significant drop in voltage will result in the ECU undergoing a reset that will stop the engine from running. As a result, it is important that the battery is in good condition and suitable for the application. Also, make sure that all wiring to the battery and associated terminals are clean and free from corrosion.

## 6.3 – +14V AUX 9/10

Note: this applies to V88 ECU's only.

The +14V Aux 9/10 wire provides an external power supply to the Aux 9 and Aux 10 driver circuitry. This allows external disconnection of the supply to these drivers as a safety measure when electronic throttle control is used. If electronic throttle control is not being used connect this wire to the same power supply as the ECU's +14V in wire as shown in Figure 6.1. If wiring with electronic throttle control, refer to the Electronic Throttle Control section of this manual.

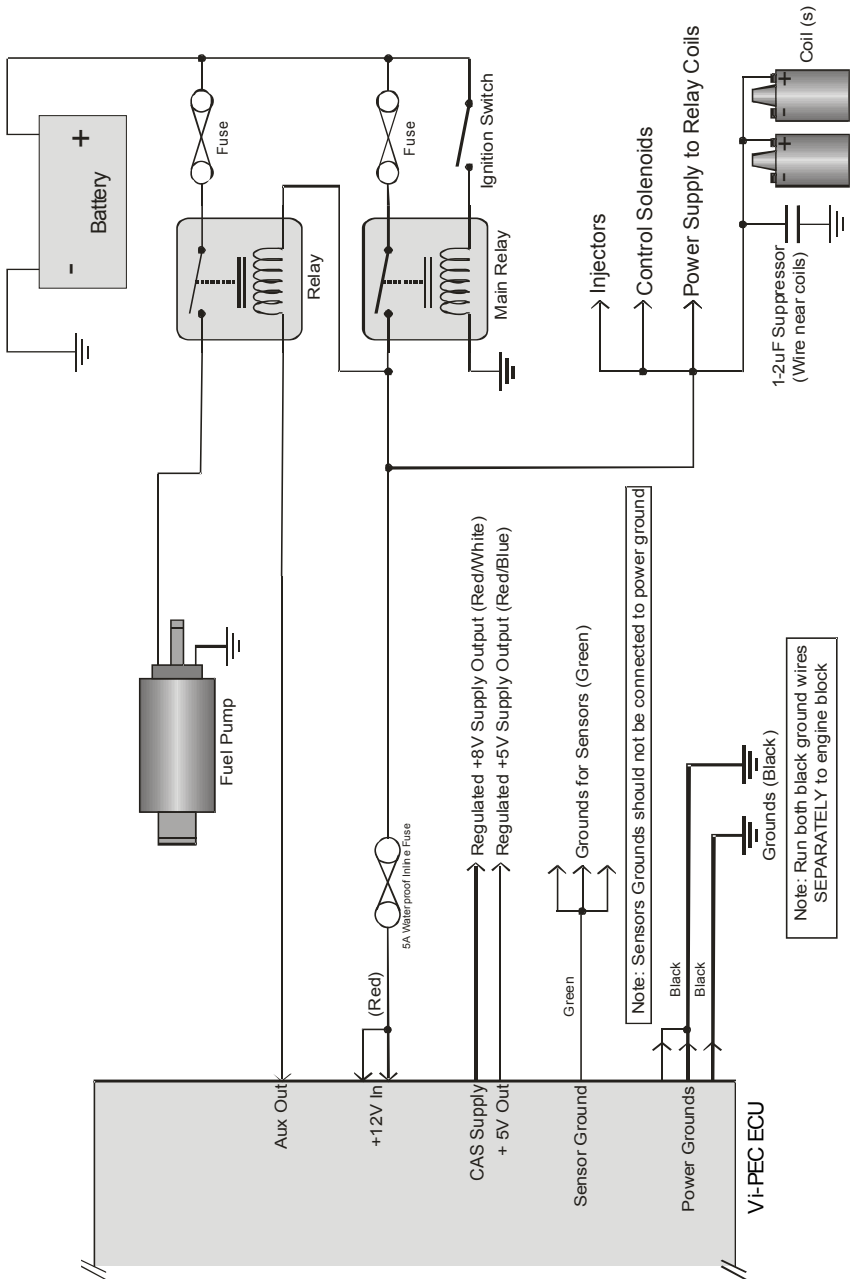

**Figure 6.1 – Standard Power and Ground Wiring (non E-throttle)**

## 6.4 – POWER GROUND

These wires supply the high current earth for the output drives. Since these wire will carry substantial currents, ensure they are well terminated to a clean earth point **on the engine block**. It is also essential that there is a good clean connection between the engine block and battery negative terminal.

**IMPORTANT!**

The Power Grounds **MUST** be run as **SEPARATE** wires. **DO NOT** be tempted to join them together at the ECU and run as a single wire. Also beware of poor earth points around the engine. Some manifolds and other attaching parts may be rubber mounted and therefore have poor earth bonding. A good rule of thumb is to use the engine **BLOCK** or **HEAD** rather than attaching parts.

## 6.5 – SENSOR GROUND

These wires are used to supply a ground reference for the sensors used by the VX ECU. As such, it is **ESSENTIAL** that these wires are used for all sensors that require a ground (e.g. throttle position sensor, water temperature sensor, etc.). Failure to do this may result in unstable sensor readings causing erratic ECU operation. **Do NOT** be tempted to ground sensors to the engine block unless it is absolutely necessary (eg single wire sensor).

**IMPORTANT!**

**Do NOT** connect any green Sensor Ground Wires to the engine block or other grounded point. This will cause current from other devices to flow in the sensor

ground wires and may result in unstable sensor readings. Most sensors are isolated from ground so this is usually not a problem. Pay particular attention to this point when connecting external controllers.

## 6.6 – +5V OUT

This wire supplies a regulated and overcurrent protected +5V to be used by sensors that operate from a 5V supply. The most common example is a throttle position sensor (TPS) and some manifold absolute pressure (MAP) sensors. Do NOT connect this wire to +12 volts or any other +5V supply.

## 6.7 – +8V OUT

This wire supplies a regulated +8V to be used for the Crank Angle Sensor (CAS) if optical or hall sensors are being used. **Do not use this wire to supply power for other devices.** Care must be taken as some optical and hall sensors are designed to use a 5V supply and may be damaged if supplied with 8V. If a 5V supply is required then the '+5V Out' may be used.

## 6.8 – ECU HOLD POWER WIRING

**This wiring method is only used when an Idle Speed Control (ISC) Stepper motor is wired.** This wiring method allows the ECU and engine management system to remain powered after the key has been switched off. This allows the ISC stepper motor to be reset to the appropriate position for the next start up. The ECU will shut down the system when reset is complete.

The other alternative is to reset the stepper motor at key-on, which can cause excessive over-rev on start up or extended cranking periods.

This wiring method is shown in Figure 6.2.

How it works:

1. The ignition switch is turned on, powering the ECU through the external diode.
2. The ECU powers up and switches the ECU and Main Relays on.
3. All systems are powered through the relays now and run as normal.
4. When the ignition switch is turned off, the ECU senses this through its Digital Input.
5. The ECU resets the stepper motor to its default position, then shuts off the ECU and Main relays when it is ready causing the system to power down.

The following items must be setup in Vi-PEC Tuning Software when using this wiring. This should be done on the bench before installing the ECU to prevent damage to the diode as it will be powering the system until ECU hold power is set up.

- The appropriate Digital Input must be configured as 'Ignition Switch'.
- The appropriate Auxiliary Output (or Ignition or Injection channel) must be configured as 'ECU Hold Power'.
- The ISC Control 'Stepper Reset' function should be set to 'Key OFF'.

The correct operation of this wiring system can be tested by listening for a pause of a few seconds between switching the key off and the ECU and Main relays switching off. The ISC stepper motor may also be heard operating during this period.

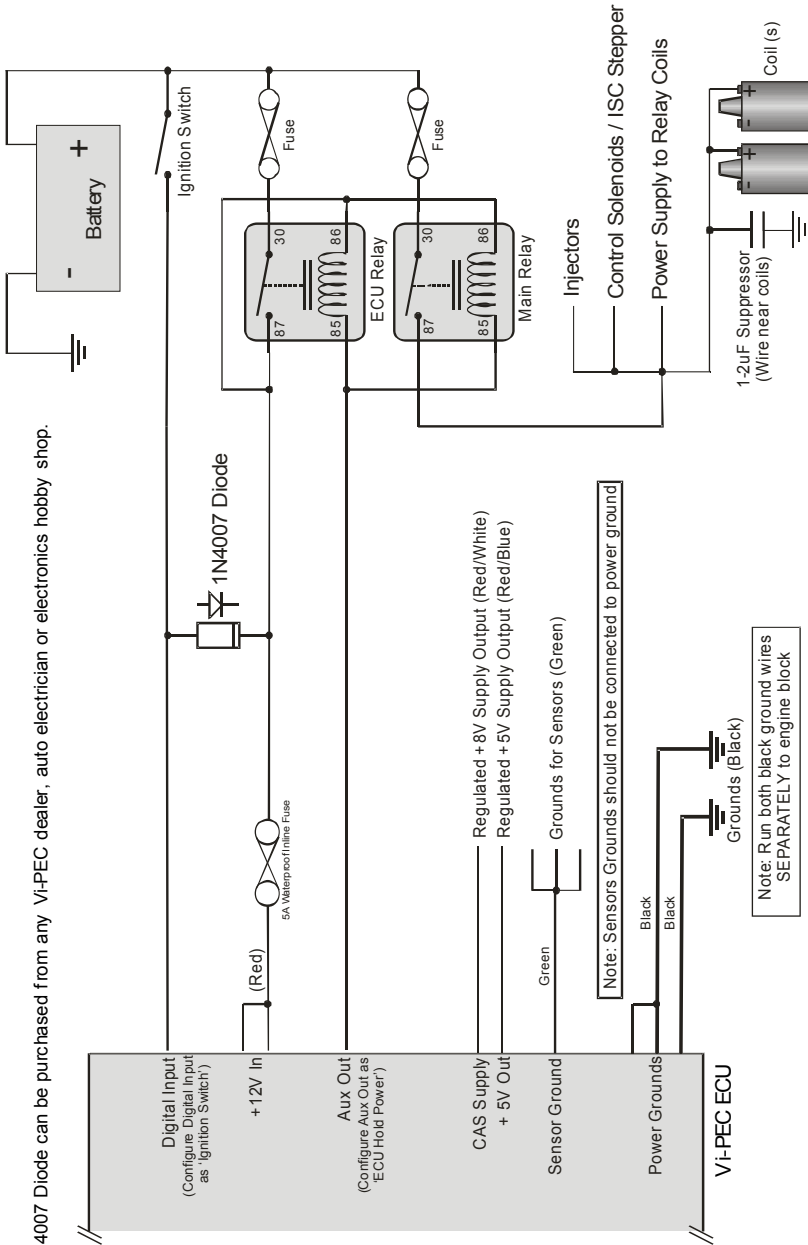

A 1N4007 Diode can be purchased from any Vi-PEC dealer, auto electrician or electronics hobby shop.

**Figure 6.2 – Power and Ground Wiring for ECU Hold Power**

# 7 – INPUT SIGNAL WIRING

---

The following sections describe wiring of the various types of sensors used as inputs to the VX ECU.

## 7.1 – TRIGGER INPUTS

Trigger inputs are required for the VX ECU to calculate engine speed as well as engine position. In all but the most basic applications both Trigger 1 and Trigger 2 must be used. These must be connected to crankshaft or camshaft angle sensors to provide the required information.

- Trigger 1 is used to determine crankshaft position.
- Trigger 2 is used to determine the engines position in the firing order (cam position). Often called the sync signal.
- Digital Inputs may be required for Variable Valve Timing camshaft position sensors (Refer to Digital Inputs Wiring for more information).

In applications using direct spark or sequential injection, Trigger 2 must always be driven from a sensor on the **camshaft** or a sensor using a trigger wheel that performs one revolution for each 720 degree engine cycle. For most wasted spark applications, only a crank sensor will be required.

The Trigger 1 and Trigger 2 cables each include two wires surrounded by a braided shield. These have the following functions.

### Trigger 1 Cable (BLACK)

Black - Sensor signal input  
White – Sensor Ground

## Trigger 2 Cable (GREY)

Red - Sensor signal input

White – Sensor Ground

The braided shield in both cables **MUST** not be grounded at the sensor end. If the sensor has its own shielded wire connection, make sure this does not connect directly to the engine block.

There are a large number of triggering variants used by different engine manufacturers. The important differences are the type of sensors used, the number of pulses sent from the sensors during an engine cycle and the timing of the pulses in relation to the engine cycle. There are two main types of sensors that are commonly used. It is important that the sensor type is known, as the wiring for each type is completely different.

**Reluctor/Magnetic** sensors have a toothed trigger wheel that passes across the face of the sensor. The movement of the teeth past the sensor generates a voltage in the sensor's winding. These sensors usually have two wires as the sensor itself generates a voltage. One wire is the sensor ground while the other is the signal output. Some reluctor sensors have a second ground and therefore have three wires. These sensors are often identified by sharp tooth profiles.

### IMPORTANT!

The polarity of the reluctor sensors two wires is very important and must be correct. Wiring of sensors incorrectly could result in erratic running and possibly engine damage

Reluctor sensors MUST be wired so that the ECU sees a positive voltage as the tooth approaches the sensor and a negative voltage as the tooth leaves the sensor. An oscilloscope is usually required to determine correct reluctor polarity.

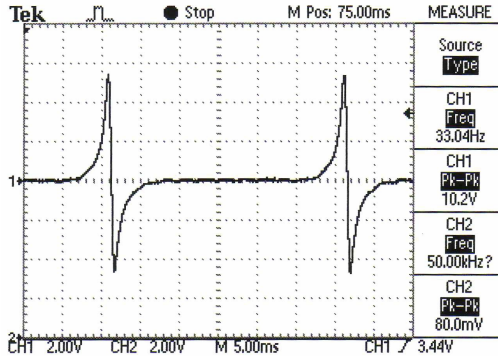

**Correct Reluctor Polarity**

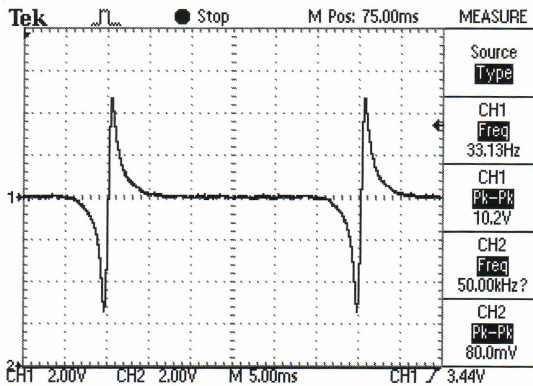

**Incorrect Reluctor Polarity**

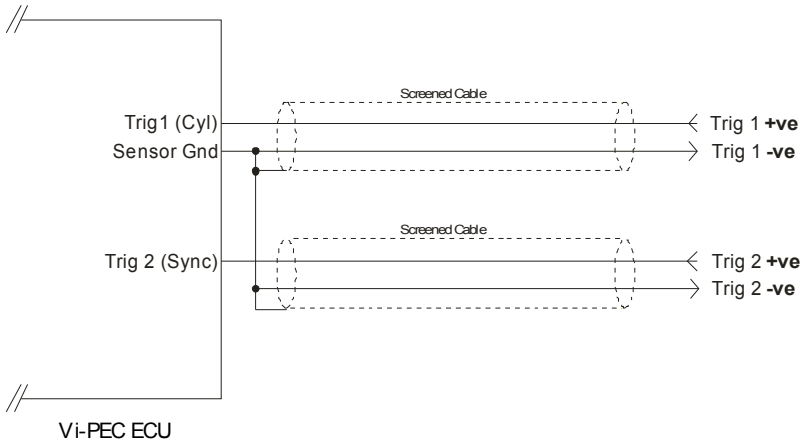

**Figure 7.1 – Reluctor Sensor Wiring**

**Optical/Hall** sensors have a slot to allow a trigger wheel to pass through. These sensors typically use a trigger wheel with slots or tabs cut out to generate pulses. These sensors require a power supply and typically have three wires.

The +8V Supply offers a regulated 8V for optical or hall sensors. These wires are not used for reluctor sensors. Note: many hall sensors will not tolerate 12V and require a 5V or 8V regulated supply.

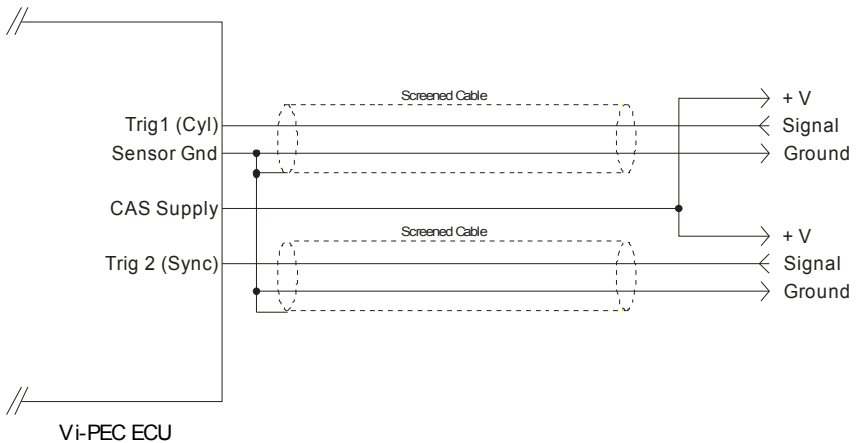

**Figure 7.2 – Optical/Hall Sensor Wiring**

Most optical or hall sensors will require the 'Trigger Pullup Resistors' to be turned on in. This is done in the 'Trigger 1' and 'Trigger 2' menus in Vi-PEC Tuning Software.

## 7.2 – MAP SENSOR

A MAP sensor will be required in all cases except for naturally aspirated engines with very aggressive camshaft profiles. The MAP fluctuations caused by large amounts of overlap result in a very unstable MAP reading especially at idle. Also note that multi-butterfly engines often give a poor vacuum signal. In these cases, it is best to use the throttle position (rather than MAP) to indicate the engine load. In all cases where forced induction is used, a MAP sensor is required.

V44 ECU's have an internal 2.5 Bar Absolute MAP sensor. If a higher pressure MAP sensor is required, an external MAP sensor can be wired to an Analog Volt input. Connect the MAP pressure hose to the barbed fitting on the ECU's endplate.

V88 ECU's require the wiring and mounting of an external MAP

sensor (if a MAP sensor is to be used).

The MAP sensor must be connected to the inlet manifold via a suitable length of 3mm (minimum size) vacuum hose. The take off point must be between the engine and throttle plate so that the MAP sensor registers vacuum (as well as pressure on turbo applications). The take off point must be from a common chamber that is connected to all cylinders rather than off a single intake runner. The fuel pressure regulator's pressure signal is usually a good take-off point. However, do not be tempted to share the MAP sensor vacuum hose with other devices such as a boost gauge or in particular a blow off valve. Figure 7.3 shows the most suitable take-off points.

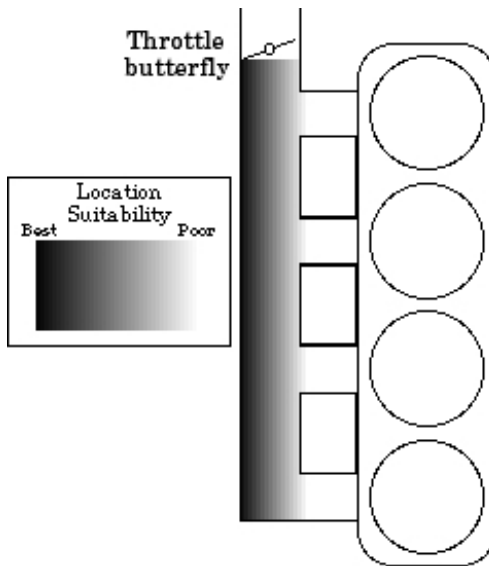
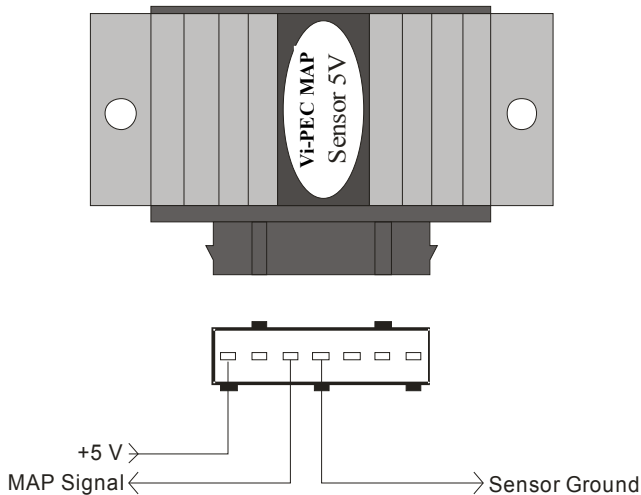

**Figure 7.3** - Suitable manifold take off points for MAP sensor hose

Ideally the MAP sensor should be mounted higher than the inlet manifold so that moisture will not condense in the MAP sensor.

## MAP Sensor Wiring:

- A MAP sensor can be wired to an Analog Volt input. Configure this input as MAP sensor and select the appropriate calibration in Vi-PEC Tuning Software.
- The ECU's +5V Out can be used to power +5V MAP sensors
- The MAP sensor MUST be grounded back at the ECU using a green Sensor ground wire, not the engine block.



**Figure 7.4 – Vi-PEC MAP Sensor Wiring**

## 7.3 – THROTTLE POSITION SENSOR

A Throttle Position Sensor (TPS) is connected directly to the end of the throttle shaft to measure the current angle of throttle opening. Even if the throttle position sensor is not required for load sensing, it is still highly recommended to use one. Throttle position is used for a number of other functions including:

- ✓ Acceleration enrichment (much better than using MAP)
- ✓ Overrun fuel cuts
- ✓ Idle Speed Control
- ✓ Boost Control (in some cases)
- ✓ Anti-Lag

## IMPORTANT

The throttle position sensor must be a potentiometer (variable resistance) and operate over the entire range of throttle movement. Partial range sensors and idle/full-throttle switches are not suitable and may not be used with VX ECU's.

Ensure the TPS mounting position allows the throttle to move through its full range of motion. The TPS should be adjusted so that it is not reaching the end of its movement at either closed throttle or full throttle. An ideal output voltage range is 0.5 to 4.5 volts. Note that the ECU will interpret a 0V or 5V signal on the TPS channel to be an error condition.

A typical TPS has 3 terminals. To wire either the factory TPS or a custom fitted sensor, an ohmmeter is required. Two of the terminals will show a fixed resistance as the TPS is moved. Connect these terminals to the 5V Out wire (Red/Blue) and Sensor Ground wire (Green) on the Vi-PEC ECU. The orientation of the +5V and ground does not matter. The result is that the TPS output will either increase or decrease in voltage with throttle position. The ECU will automatically detect this so either option is acceptable. The third terminal must show a variable resistance between it and the ground terminal as the throttle position is changed. This is the TPS output and should be connected to any Analog Volt input. This is shown in Figure 7.5.

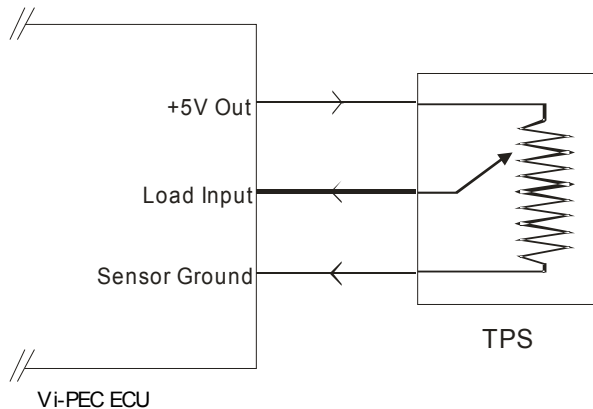

**Figure 7.5 - TPS Wiring**

## 7.4 – ENGINE COOLANT TEMPERATURE (ECT)

Engine coolant temperature is required primarily for fuel enrichment during cold starting and during the warm-up period that follows. This sensor should always be mounted on the engine side of the thermostat.

VX ECU's can measure the temperature using a thermistor (NTC or PTC) sensor or a sensor with a 0-5V output. Any sensor calibration is permitted.

Thermister sensors have a resistance that changes with temperature and are commonly used in automotive applications. When wiring thermistor sensors the polarity is NOT important. **An Analog Temp wire should be connected to one terminal on the sensor while the other terminal must be connected to the Sensor Ground (green) wire.**

When using a sensor that produces a 0-5V output or in piggy back application where a factory ECU is already providing the temperature sensor pullup resistor, connect the ECT signal to an Analog Volt channel.

VX ECU's are compatible with any NTC or PTC thermistor sensor. The recommended sensor is a Bosch 0 280 130 026 sensor. A number of pre-calibrated sensor options are also provided in Vi-PEC Tuning Software. Note that most factory sensors will use the Standard Bosch NTC calibration. In order to use a sensor with a different calibration you will need to know how the sensor's resistance changes with temperature and enter this information into the ECU via Vi-PEC Tuning Software.

## 7.5 – INLET AIR TEMPERATURE

Using an inlet air temperature sensor allows fuel and ignition corrections to be made for changes in the temperature of the air entering the engine. The air temperature sensor must be setup to most accurately measure the temperature of the air entering the engines combustion chambers. On a naturally aspirated engine this normally means any position between the air filter and inlet manifold. However, on a turbocharged/supercharged engine the sensor must be placed **AFTER** the turbocharger and any intercooler.

On most applications (both naturally aspirated and turbocharged) the recommended mounting position is in the inlet pipe just before the throttle plate. The sensor may also be placed in a section of the inlet manifold that is subject to high airflow. However, in some applications the inlet manifold may get very hot and heat soak the sensor causing a reading that is not representative of the air entering the combustion chambers.

It is very important on a turbocharged/supercharged engine that the air temperature sensor can react fast enough to track the rapidly changing temperature. For this reason, an open element sensor is required. The recommended sensor is a Bosch 0 280 130 085. On naturally aspirated engines this sensor may be

substituted for a 0 280 130 039, which is cheaper and easier to fit.

VX ECU's are designed to measure the temperature using a thermistor sensor. These sensors have a resistance that changes with temperature and are commonly used in automotive applications. When wiring thermistor sensors the polarity is NOT important. **The Inlet Temperature Sensor must be connected to the Sensor Ground (green) wire and an Analog Temp wire.**

VX ECU's are compatible with any NTC or PTC thermistor sensors. The default calibration is for either of the Bosch sensors listed above. In order to use a sensor with a different calibration you will need to know how the sensor's resistance changes with temperature and enter this information into the ECU via Vi-PEC Tuning Software. Note that most commonly used sensors calibrations are available by selecting them in Vi-PEC Tuning Software.

## 7.6 – NARROW BAND OXYGEN SENSOR

A narrow-band exhaust gas oxygen (EGO) sensor is very accurate at air/fuel ratios near 14.7:1 (for petrol). At richer or leaner air/fuel ratios there is a very small output signal change for large changes in air/fuel ratio. This makes the narrow-band sensor very good at detecting either a lean or rich condition, but not very useful for detecting how lean or rich. For this reason, a narrow-band sensor is not recommended for tuning purposes. However a narrow band sensor is suitable for running Closed Loop Lambda (CLL). CLL allows the ECU to self tune at cruise to improve economy and emissions.

There are many variations of EGO sensors although most are identical in terms of the output signal. The principal differences

are mostly physical involving lead tolerance, heated or unheated, mounting methods, and whether or not a signal ground wire is supplied.

### 7.6.1 – LEAD TOLERANCE

The lead additives used in most high-octane fuel (aviation gas or race gas) will reduced the lifespan of the sensor considerably. Some probes are shielded and are more tolerant than others.

### 7.6.2 - HEATING

Many probes incorporate an electrical heating element, which is powered by the vehicles 12 Volt supply. These heaters allow the probe to be mounted in cooler portions of the exhaust system and significantly improve the probe performance at idle and during warm up phases of operation. This is because the probe temperature must exceed 300°C before accurate readings are possible.

An Auxiliary Output can be used to control the heating of the oxygen sensor if required. To do this, ground the sensors heater wire through any of the ECU's auxiliary channels.

### 7.6.3 - MOUNTING

Most probes have an M18 x 1.5 metric thread designed to screw into a mating boss. Some variants use a bolted flange arrangement, but these are relatively uncommon.

Almost all EFI engines will have a probe installed as original equipment in the exhaust manifold or turbo housing.

If the vehicle does not have a factory fitted EGO sensor, it will be necessary to manufacture a sensor mount according to engine type and layout.

The ideal mounting position of the sensor in the exhaust can vary depending on the application. Most of the time the preferred position is in the exhaust manifold collector on a naturally aspirated engine or after the turbocharger on a turbocharged engine. However, a location further down the exhaust is acceptable provided the probe is adequately heated. Note that it is also possible to get an EGO sensor too hot which also causes an inaccurate reading. Therefore in applications with particularly high exhaust gas temperatures (e.g. turbo engines, rotary engines) it may be necessary to either use an unheated sensor or move a heated sensor further down the exhaust.

Caution: EGO sensors use ceramic material internally and are susceptible to impact damage. Handle probes carefully to avoid impacts at all times.

#### 7.6.4 – OXYGEN SENSOR WIRING

Typically narrow-band EGO sensors can be recognised as having one, two, three or four wires. These have the following functions.

**Single Wire Sensor** - The wire is the signal output and should be connected directly to an Analog Voltage Input.

**Two Wire Sensor** - One wire for the signal output (to Analog Voltage Input). The other is the signal ground (Signal Ground (green)).

**Three Wire Sensor (Heated)** - One wire for the signal output (to Analog Voltage Input). Two wires for the heater. One of the heater wires should be connected to an ignition switched 12V supply. The other heater wire can be connected to a convenient ground (or controlled using an auxiliary output). Heater polarity is

not important.

**Four Wire Sensor (Heated)** - As for three wire sensor, but with an extra wire for the signal ground which must be connected to Sensor Ground (green).

The recommended narrow-band EGO sensor is a Bosch 3-wire lead-tolerant unit with Part Number 0 258 003 070. As with other Bosch 3 wire sensors, the wire colours are:

2 white wires	=	heater (18 watts)
1 black wire	=	output signal

## 7.7 – WIDE BAND OXYGEN SENSOR

Wide-band exhaust gas oxygen (EGO) sensors are able to accurately measure air/fuel ratios over a very wide range from very lean to very rich. This makes these devices very suitable for tuning purposes.

A wideband sensor can be used to run Closed Loop Lambda (CLL) for improved economy and emission. A wideband sensor is a necessity if Quick Tune (refer to the Vi-PEC Tuning Software online help) is going to be used to tune the engine.

Any Analog Volt channel may be used to accept the signal from a wide-band EGO sensor controller. Note that VX ECU's cannot accept the signal directly from a wide-band sensor. A wide-band controller works as an interface between a wide-band O2 sensor and the ECU. The controller should connect directly to the sensor and output a voltage between 0 and 5V.

The sensor calibration (the voltages that correspond to given air/fuel ratios) must be known and this information must be entered into the ECU via Vi-PEC Tuning Software.

## 7.8 – GP PRESSURE AND TEMP SENSING

Any Analog Volt channel may be used as inputs from additional general purpose (GP) pressure and temperature sensors. The only restriction is that the sensor must have a 0-5V output. The sensor calibration (the voltages that correspond to given pressures/temperatures) must be known and this information must be entered into the ECU via Vi-PEC Tuning Software.

GP Pressure and Temperature Sensor Wiring:

- Signal – Analog Volt Channel
- Power – As per sensor manufacturers spec (can use ECU's +5V out)
- Ground – Ground to ECU's Sensor Ground.

### CAUTION

Do not use a sensor designed to measure air pressure to measure fuel, oil or water pressures. Consult the sensor manufacturers specifications.

## 7.9 – DIGITAL INPUT WIRING

Digital inputs may be connected to switches to control various functions including launch control (clutch switch), anti-lag, high/low boost, water spray, dual fuel/ignition maps, nitrous oxide, air conditioning request and anti-theft.

Figure 7.6 shows the two methods of wiring Digital Inputs to a switch. When wiring other devices such as controllers it will be necessary to determine if these devices are active low or active high. If a switch or controller drives low then the Digital Inputs 'Pullup Resistor' will need to be enabled in Vi-PEC Tuning Software.

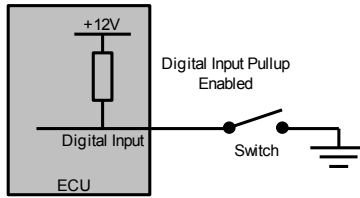

**Figure 7.6a** - Wiring of a Drive Low Switch to a Digital Input

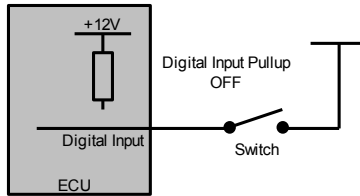

**Figure 7.6b** - Wiring of a Drive High Switch to a Digital Input

### 7.9.1 – VEHICLE SPEED INPUT

Speed signals should only be connected to Digital Inputs 1 to 6.

Vehicle Speed may be calculated using the output from a digital speedometer drive or in some cases from the speedometer assembly itself. This may be connected directly to a Digital Input. Some sensors will require that the Digital Inputs 'Pullup Resistor' is enabled in Vi-PEC Tuning Software.

### 7.9.2 – VVT CAM POSITION INPUT

Continuously Variable Valve Timing (CVVT, VVT, VVTi, AVCS) Cam Position digital inputs can only be connected to Digital Inputs 1 to 4.

Reluctor or Optical/Hall sensors can be used to measure camshaft position on engines equipped with CVVT systems.

CVVT position sensors should be wired to digital Inputs in the same manner as Trigger signals (Refer Figures 7.1 and 7.2). This includes the use of Sensor ground and shielded cables. Shielded cable for Digital Input wiring is not included in the standard loom but can be purchased from your Vi-PEC dealer. Not using sheilded cable can result in cam shaft position measurement errors.

For engine specific information on the wiring of triggers and VVT position sensors refer to your Vi-PEC dealer or [www.Vi-PEC.com](http://www.Vi-PEC.com).

Although not absolutely necessary, it is recommended to ease configuration that cam position signals are wired to the same number Digital Input channel as the corresponding solenoid control Auxiliary Output (refer following table). For compatibility, the following use of Digital Inputs and Auxiliary outputs is recommended for VVT wiring. Note that in practice any Digital Input/Auxiliary Output combination can be used.

Cam Shaft	Digital Input	Auxiliary Output
Inlet or Inlet LH	DI 1	Aux 1
Inlet RH	DI 2	Aux 2
Exhaust or Exhaust LH	DI 3	Aux 3
Exhaust RH	DI 4	Aux 4

In cases where the same camshaft position signal is used to measure camshaft timing as well as provide sync (firing order position) information, this sensor will usually be wired to Trigger 2.

## 8 – OUTPUT WIRING

---

The following sections describe wiring of output devices to VX ECU's.

### 8.1 – FUEL INJECTOR DRIVES

For information on wiring Injection outputs as additional Auxiliary Outputs, refer to Section 8.5.

The injector drives on a VX ECU's work by supplying an EARTH to turn the injectors on. A switched (key ON) 12V (refer to Figure 6.1) must be supplied to the other terminal of the injector. The polarity is not important.

#### WARNING

DO NOT connect +12V directly to any of the injector drives.

Injectors are commonly available as either high impedance or low impedance. To determine injector impedance: With the injector unplugged, use an ohmmeter to measure the resistance across the two terminals of the injector;

- If the injector resistance is greater than 6  $\Omega$  then the injectors are high impedance and no ballast resistors are required,
- If the injector resistance is less than 6  $\Omega$  then ballast resistors will be required.

#### 8.1.1 – HIGH IMPEDANCE INJECTORS

VX ECU's can drive up to two high impedance injectors off each Injector Drive. **It is recommended to wire a single injector to each injector drive.** On engines with more cylinders than the

ECU has Injection Drives injectors should be paired.

Wiring for high impedance injectors is shown in Figure 8.1.

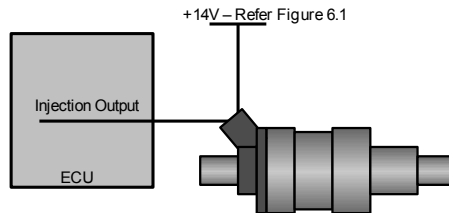

**Figure 8.1 – High Impedance Injector Wiring**

### 8.1.2 – LOW IMPEDANCE INJECTORS

V88 ECU's can drive low impedance injectors directly as shown in Figure 8.1. When driving low impedance injectors directly it is essential that before running the engine the correct Injection Mode (Peak and Hold) and Peak and Hold Currents are configured using Vi-PEC Tuning Software.

V44 ECU's have saturated injection drivers only. This means that:

**Low impedance injectors can NOT be wired directly to a V44.**

To use a V44 on an engine equipped with low impedance injectors, ballast resistors must be installed as described in the following section. Note that most vehicles factory fitted with low impedance injectors will have factory fitted ballast resistors.

### 8.1.3 – WIRING BALLAST RESISTORS

V44 ECU's can drive up to 2 low impedance injectors on one Injection Drive WITH BALLAST RESISTORS FITTED. Ballast resistors must be used to limit the current through the injectors and injector drive to avoid damage.

### WARNING !

DO NOT WIRE LOW IMPEDANCE INJECTORS DIRECTLY TO THE V44 ECU'S INJECTOR DRIVES WITHOUT USING BALLAST RESISTORS AS DESCRIBED IN THIS SECTION.

**It is recommended to wire a single injector to each injector drive.** On engines with more than eight cylinders injectors should be paired.

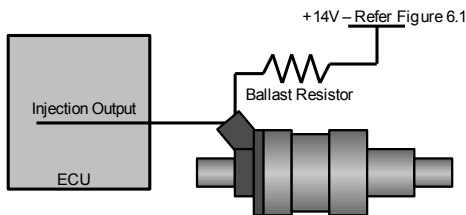

**Figure 8.2 - Injector wiring for injectors with ballast resistors**

If the injector impedance is LESS THAN 2 Ohms, use 2R2 (2.2 Ohm) ballast.

If the injector impedance is between 2 and 6 Ohms, use 4R7 (4.7 Ohm) ballast.

If the injector impedance is greater than 6 Ohms, use no ballast.

It should be noted that injector ballast resistors get quite hot at high injector duty cycles. Therefore these should be mounted on a heat sink and this should be bolted to the chassis. Typically ballast resistors should be mounted in the engine bay.

Do not use common 0.25 W or 1.0 W resistors, as these will burn out almost immediately. 50 W resistors should be used. These are relatively uncommon at hobbyist shops, but are readily available from your Vi-PEC dealer in groups of 2, 4, 6 or 8 resistors on a heat sink.

## 8.1.2 – INJECTION MODE

The VX ECU's have up to eight independent injector drives. This means that for most engines sequential injection can be used. Depending on the number of Injection Drives, the following Injection Modes may available:

- Single Point Group
- Sequential
- Multi Point Group
- Sequential/Staged
- Group/Staged

## 8.1.3 – SINGLE-POINT GROUP INJECTION

A single injector (sometimes two) is used to supply fuel for all cylinders. Normally this injector is placed just before or just after the throttle body. In this mode the injector(s) are fired once per TDC. The injector should be driven by Injector Drive 1. If two injectors are used then the second injector should be driven by Injector Drive 2.

## 8.1.4 – MULTI-POINT GROUP INJECTION

This mode should be used if each cylinder has its own injector, but there are too many cylinders or insufficient triggering to use sequential injection. In this mode the injectors are fired in two out-of-phase groups with each group firing once for every 360 or

720 degrees of crankshaft rotation (depending on the Injection Rate setting). Wire each injector to its own drive or pair injectors if there are not enough drives.

### 8.1.5 – SEQUENTIAL INJECTION

This mode should be used if each cylinder has it's own injector providing the following criteria are met:

1. There must be one Injector Drive for each cylinder.
2. There must be sufficient triggering for the ECU to calculate the current engine position in the 720 degree engine cycle. This means that a second trigger sensor is required for synchronisation and this must use an appropriate trigger wheel driven off of the camshaft (or driven at half the crankshaft's angular speed).

In this mode each injector must be correctly wired to its own injector drive so that the injector can be fired. The timing at which the injectors fire is configurable within Vi-PEC Tuning Software.

The firing order of the engine is NOT important at the wiring stage as the firing order will be entered into the ECU via Vi-PEC Tuning Software. Wire each cylinder to its corresponding injector drive number (wire cylinder 1 injector to injector drive 1, 2 to 2, 3 to 3 etc...).

Set the 'Injection Mode' to 'Sequential' when using this configuration.

### 8.1.6 – STAGED INJECTION

This mode allows the use of staged injection where the engine uses primary injectors that operate at all times and secondary

injectors that only operate at high load/rpm. This arrangement is useful in applications with very high fuel delivery requirements that would normally require extremely large injectors. Very large injectors make tuning difficult at low loads (idle and low power operation). With staged injection one smaller set of injectors operates at low load giving more precise control. At higher loads both sets of injectors become active to supply the required fuelling needs.

## **Group Fire Staged Injection**

This mode must be used for staged injection if the criteria required for sequential injection are not met (refer Section 8.15). In this mode, wire the primary injectors to any of the odd numbered Injector Drives (Inj1, Inj3, Inj 5, Inj7), wire the secondary injectors to any of the even numbered Injector Drives (Inj2, Inj4, Inj6, Inj8). In this mode all primary injector drives are fired at the same time (group fire) and all secondary injector drives are fired at the same time (group fire). Set the 'Injection Mode' to 'Group/Staged' when using this configuration.

## **Sequential Staged Injection (V88 only)**

This mode can be used to provide full sequential injection on both the primary and secondary injectors. This mode requires that the engine have sufficient triggering to calculate crankshaft position and the position in the firing order (ie a sync signal is required). This mode can only be used on engine with four cylinders or less. Wire injectors as shown in the following table:

Set the 'Injection Mode' to 'Sequential/Staged' when using this configuration.

Injection Channel	Cylinder Number
1	1 - Primary
2	2 - Primary
3	3 - Primary
4	4 - Primary
5	1 - Secondary
6	2 - Secondary
7	3 - Secondary
8	4 - Secondary

## 8.2 – IGNITION DRIVES

For information on wiring Ignition Channels as Auxiliary Outputs refer to Section 8.5.

VX ECU's have up to 8 independent ignition drives which can be used in a wide range of configurations from a basic distributor setup through to more complex multi-coil arrangements. VX ECU's support the ignition configurations shown in Table 8.3.

Number of Cylinders	Distributor	Wasted Spark (1 Dual Post Coil per two Cylinders)	Direct Spark (1 Coil per Cylinder)
2	✓	✓	✓
3	✓	x	✓
4	✓	✓	✓
5	✓	x	✓ *
6	✓	✓	✓ *
8	✓	✓	✓ *
10	✓	✓ *	x
12	✓	✓ *	x

\* V88 only

**Table 8.3** - Available Ignition Combinations

### 8.2.1 – IGNITER REQUIREMENTS

An igniter acts as an interface between the ECU and the ignition coil(s). The Igniter is used to drive the coil(s) by supplying a ground for the coils negative terminal. Wiring of an igniter and coil is shown below in Figure 8.3.

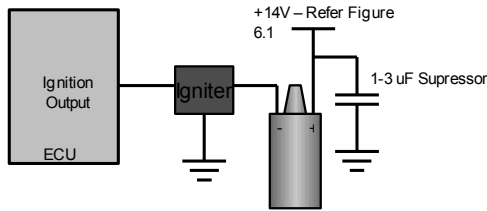

**Figure 8.3** - Wiring of igniter and coil

The igniter is basically a solid-state switch, which may also limit the coil current to a predetermined value. This limiting feature eliminates coil ballast resistors and provides protection of the coils if the dwell time (time the coil is charged for) is set too long. Over voltage clamping is incorporated to prevent damage to the igniter should a high-tension lead become disconnected or similar.

Each one of the ignition drives may be used to switch a separate channel on an igniter. Each channel on the igniter is used to switch an ignition coil. The following examples show the requirements for some common ignition configurations:

**Example** - 4 cylinder engine with direct spark

- Four ignition drives must be used
- A four channel igniter (or 2 x 2 channel igniters) must be used
- Four Single Post Coils must be used

**Example** - 4 cylinder engine with wasted spark

- Only two ignition drives are used (Ign 1 and Ign 2)
- One two channel igniter must be used
- Two Dual Post Coils must be used

## **Example** - Engine with a single distributor ignition

- Only one ignition drive is used (Ig 1)
- A single channel igniter must be used
- One Single Post Coil must be used

Conventional igniters begin to charge the coil when their input is high. Spark occurs when the input goes low. This is known as a Rising 'Dwell Edge'. Many factory Ford, Honda igniters, MSD ignitions and some other units work in the opposite sense. The coil begins to charge when the input signal goes low while spark occurs on the transition from low to high. In these cases, a Falling 'Dwell Edge' must be selected in Vi-PEC Tuning Software.

Always mount igniter(s) in the engine bay as close to the ignition coil(s) as possible. This helps to minimize the length of high current wiring between the igniter(s) and coil(s).

### **NEVER mount the igniter(s) next to the VX ECU**

Avoid areas of high temperature such as exhausts, turbochargers and radiators since the igniter itself will generate heat at high power. If vibration levels will be excessively high, some form of soft or rubber mounting is advisable to prevent component and wiring fatigue.

## **8.2.2 – COIL REQUIREMENTS**

Use only coils designed for high-energy transistor/inductive ignition systems. The coils primary resistance must be between 0.4  $\Omega$  and 1.0  $\Omega$ . This applies to both single and dual post coils in distributed and multi coil applications.

## 8.2.3 – IGNITION SUPPRESSION

Without exception ALL ignition systems must be suppressed. Failure to do so may cause the ECU to behave erratically, especially at high power. Symptoms include misfiring, erratic RPM readings and the ECU performing repetitive resets. The following rules must be followed:

- Unsuppressed H.T. leads act as aerials and radiate very powerful interference signals. ALL applications must use suppression leads, preferably resistance type rather than spiral wound or inductive. Typically these vary from 1000 ohms to 5000 ohms depending on lead length. NEVER use plain wire leads.
- ALL applications must also employ a suppressor capacitor (0.5 - 3uF) connected directly between the ignition coil(s) POSITIVE terminal and ground. Most points condensers are suitable. Multiple coils can share a single suppressor. 'V' and boxer engines with multiple coils must have a suppressor on each bank.
- Isolate the ignition system as much as possible from other sensitive devices, especially the ECU. Do not run non-ignition related wiring close to igniters, coils or HT leads wherever possible. Maintain maximum distance from radio transmitters and coaxial cables etc.
- Always use resistor spark plugs. These can be checked by measuring the resistance between the top of the spark plug and the centre electrode. On a resistor plug the resistance will be several thousand ohms.
- If insufficient ignition energy is causing a high-power misfire (especially on turbo/super charged engines), it may

be necessary to reduce the spark plug gap. Gaps as small as 0.5mm (.020') may be necessary. This also reduces the amount of radiated electrical noise due to the lower firing voltage.

- Keep the input wiring to the igniter (from the ECU) separate from the output wiring of the igniter (to the coil(s)) as shown in Figure 8.5.

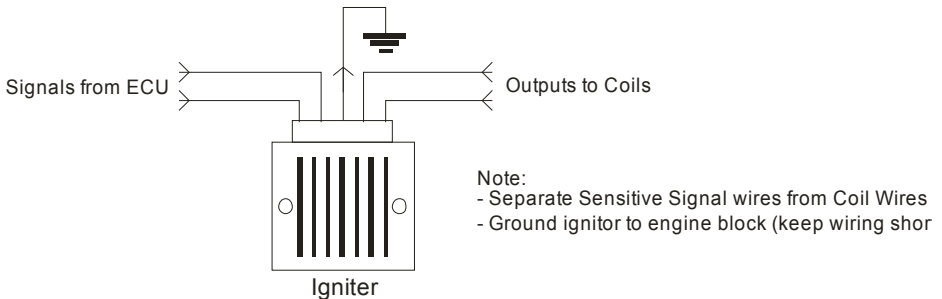

**Figure 8.5 - Separation of igniter input and output wiring**

## 8.2.4 – DISTRIBUTOR IGNITION

A distributor rotates at half the crankshaft speed and routes the high voltage generated by the coil to the intended spark plug via a rotor and HT wiring. A distributed engine requires one ignition drive and a single channel igniter. Use Ignition Drive 1 to switch the igniter.

Because the rotor will only point to each post on the distributor cap for a short amount of time, the rotor timing dictates the range of ignition advance angles that may be used without misfiring or unnecessarily losing spark energy. A wider tip on the rotor will also allow a wider range of timing values to be used. The tip of rotor should be just leaving the post when the crankshaft is positioned at the minimum timing that will be used (typically at about 10 degrees BTDC). The point where the leading tip of the

rotor arrives at the post is the most advanced timing that should be used. These positions are shown in Figure 8.7.

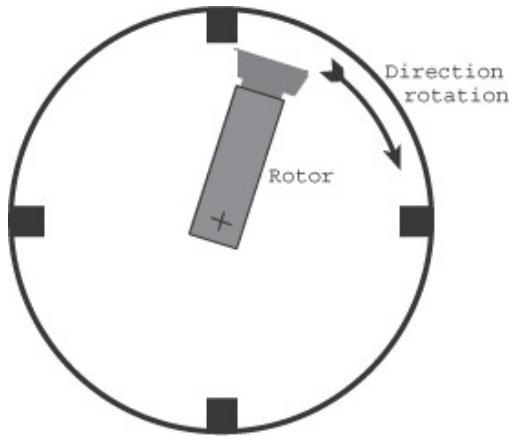

**Figure 8.7 - Correct Rotor Timing**

### 8.2.5 – MULTI-COIL: WASTED SPARK

Wasted spark will fire two cylinders simultaneously, using a common dual post coil. When a dual post coil is fired, two cylinders receive a spark. One cylinder is fired conventionally on the compression stroke while the other cylinder has its piston in the same position but on the exhaust stroke. One crankshaft rotation later, these two cylinders are two working strokes further ahead and the spark plugs fire again, but now with reversed roles. The result is that each coil will be fired twice per engine cycle hence the term “wasted spark”. This setup can ONLY be used on engines with an even number of cylinders.

One dual post coil (with a primary resistance between 0.4 and 1.0 ohms) is required per 2 cylinders. Figure 8.8 shows a typical coil. The coils should be positioned so they minimise the length of the HT Leads. This will help reduce the electrical noise generated when the spark plugs are fired.



**Figure 8.8 - Dual Post Coil**

The main concern when using dual post coils is the generation of electrical interference. This can interfere with ECU operation and cause unwanted static on car radios. The ignition suppression techniques outlined earlier are particularly important. All wasted spark systems should use 'Resistive Spark Plugs' if the engine does not currently use them.

To ensure each ignition drive is matched to the correct cylinder, the firing sequence will need to be determined. Note this option is only possible when the engine has an even number of cylinders. When using a wasted spark arrangement, an ignition drive will fire cylinder pairs that are 360° apart in the firing order.

Ignition Drive 1 always needs to be connected to cylinder number 1 and its corresponding cylinder (360° apart in the firing order).

Ignition Drive 2 should be connected to the next cylinder in the firing order and its corresponding cylinder (360° apart in the firing order).

If more cylinders exist (6, 8, 10 & 12 cylinder engines) then the pattern should be continued. For example Ignition Drive 3 fires the third cylinder in the firing order and its corresponding cylinder.

Table 8.4 summarises this information for applications up to 8 cylinders. 1st represents cylinder number one, 2nd represents the next cylinder in the firing order etc:

Write Firing Order Below	Number of Cylinders			
	2	4	6	8
1	Ign 1	Ign 1	Ign 1	Ign 1
	Ign 2	Ign 2	Ign 2	Ign 2
		Ign 1	Ign 3	Ign 3
		Ign 2	Ign 1	Ign 4
			Ign 2	Ign 1
			Ign 3	Ign 2
				Ign 3
				Ign 4

**Table 8.4 - Wasted spark Ignition Wiring**

**Example** - Wasted spark setup for a 4 cylinder engine with 1-3-4-2 firing order.

- Ignition Drive 1 fires cylinders 1 and 4
- Ignition Drive 2 fires cylinders 2 and 3

**Example** - Wasted spark setup for a 6 cylinder engine with 1-5-3-6-2-4 firing order.

- Ignition Drive 1 fires cylinders 1 and 6
- Ignition Drive 2 fires cylinders 5 and 2
- Ignition Drive 3 fires cylinders 3 and 4

## 8.2.6 – MULTI-COIL: DIRECT SPARK

Direct spark uses an ignition coil per cylinder, firing each cylinder once per engine cycle (2 crankshaft revolutions). If multi-coil operation is required for an odd number of cylinders, the only option is to use an ignition coil per cylinder.

V88 ECU's have eight ignition drives allowing up to eight individual coils to be controlled. Therefore, this ECU may only be used on engines with eight cylinders or less with direct spark ignition.

V44 ECU's have four ignition drives allowing up to four individual coils to be controlled. Therefore, this ECU may only be used on engines with four cylinders or less with direct spark ignition.

Engines using direct spark ignition must have a way for the ECU to calculate the current order in the firing sequence. Because an engine may be at one of two possible positions in the firing sequence given a crankshaft position, a trigger wheel rotating at crankshaft speed is not sufficient for direct spark ignition. Therefore a second sensor mounted on the camshaft (or driven at camshaft speed) is required to send a sync pulse. If an engine does not have an appropriate sensor then either one will need to be fabricated or another ignition mode must be used.

Some factory set-ups using direct spark have a coil and igniter in one package, mounted on top of the spark plug. These are normally three terminal devices requiring 12 volts, ground, and the signal from an Ignition Drive.

When using a non-factory arrangement the coils should be positioned so they minimise the length of the HT Leads. This will help reduce the noise generated when the spark plugs are fired.

Each ignition drive **MUST** be connected via an igniter channel to a coil (remember some coils have the igniter built in).

### **Example** - 4 cylinder engine with direct spark

- Four ignition drives must be used
- A four channel igniter (or 2 dual channel igniters) must be used
- Four Single Post Coils must be used
- Drive the igniter for cylinder one from Ign 1, cylinder 2 from Ign 2, cylinder 3 from Ign 3 and cylinder 4 from Ign 4.

When wiring an ignition system using direct spark, the firing order of the engine is not important as it will be entered into the ECU via Vi-PEC Tuning Software.

Ignition Drive 1 must be wired to cylinder 1 coil, Ignition Drive 2 to cylinder 2, 3 to 3, etc. Figure 8.12 shows an example of how to wire direct spark ignition for a 4 cylinder engine.

## **8.3 – IDLE SPEED CONTROL**

Idle Speed Control (ISC) is required to provide an acceptable idle speed when the engine is cold or when loads (AC etc.) are applied. Without idle speed control, an engine will idle too slowly when cold. Often the cold idle speed will be so low that the engine stalls. Likewise, extra load loads will decrease the idle speed and may cause the idle to stall or become unstable. The ISC system regulates the engine idle speed by adjusting the amount of air which is bypassed around the throttle. This air may be bypassed using either a solenoid or stepper motor.

VX ECU's employ a sophisticated closed loop idle speed control system that provides factory like idle speed control. This system can be used to provide idle speed control using either a 2 or 3

terminal ISC Solenoid or a 4 or 6 terminal ISC Stepper Motor. While a solenoid and stepper motor operate very differently they both achieve the effect of bypassing air around the throttle plate to increase the idle speed.

Some engines use a non-electronic system to control idle speed as the engine warms up. This system contains a bimetallic strip, which is heated by the engine coolant and/or electrically. As the engine warms up, the amount of bypassed air is reduced and the idle is returned to its normal level. The ECU does not control this type of device. It is intended ONLY as an idle up when the engine is cold.

### 8.3.1 – TWO TERMINAL ISC SOLENOID

Note: a two terminal ISC solenoid may be wired to any Auxiliary Channel. Injection channels can not be used for ISC control. Ignition Channels 1 to 8 can also be used to control a two terminal ISC Solenoid however an external fly-wheeling diode must be wired.

Two terminal ISC solenoids need only one auxiliary output (or ignition channel) to open the solenoid. A spring is used to automatically close the solenoid. Connect one terminal to a switched +12V supply (as shown in Figure 6.1) and connect the remaining terminal to an Auxiliary/Ignition Output Output. See Figure 8.13. The orientation of the wires does not matter.

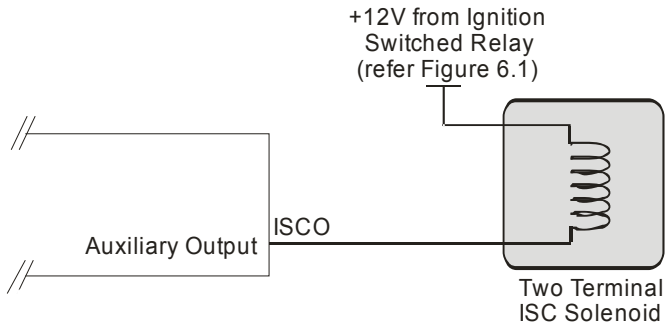

**Figure 8.13)a** - Wiring for two-terminal ISC solenoid on Auxiliary Output

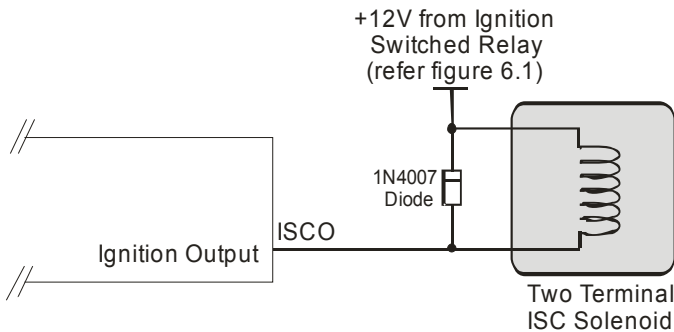

**Figure 8.13)b** - Wiring for two-terminal ISC solenoid on Ignition Output

### 8.3.2 – THREE TERMINAL ISC SOLENOID

**Note:** A Three Terminal ISC Solenoid must be wired to Aux 1 and Aux 2. Aux 1 is ISC Close, Aux 2 is ISC Open.

Three terminal ISC solenoids needs one Auxiliary Output to open the solenoid and another Auxiliary Output to close it.

Use an ohmmeter to find the common terminal (usually the centre). Figure 8.14 shows the schematic. Next measure the

resistance between the common and remaining two terminals. This should be greater than 10 ohms. Apply +12V to the common terminal of the solenoid. Ground one of the other terminals. If this terminal causes the valve to open, connect it to an Auxiliary Output 2 and note that this output should be configured as 'ISC Solenoid'. If the valve closes, connect the terminal to Auxiliary Output 1 and note that this output should be configured as 'ISC Solenoid Slave'.

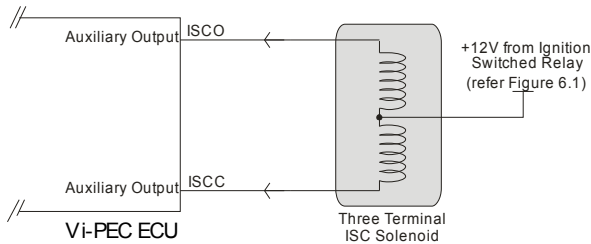

**Figure 8.14** - Three terminal ISC Solenoid Wiring

### 8.3.3 – FOUR TERMINAL ISC STEPPER MOTOR

**Note:** An ISC Stepper Motor must be wired to Aux 5, Aux 6, Aux 7 and Aux 8.

When using an ISC Stepper, the ECU's power supply should be wired for ECU Hold Power as shown in Figure 6.2. This will allow the ECU's Hold Power function to be taken advantage of. Using ECU Hold Power allows the ECU to reset the stepper motor after key off. This avoids extended cranking periods caused by resetting the stepper at key on.

Figure 8.15 shows a schematic of a four-terminal stepper motor. Note that there are two coils. Use an ohmmeter to pair the terminals with a common coil. Aux 5 and 6 must be connected to the terminals for one coil, while Aux 7 and 8 must be connected to the terminals for the other coil. If it is found that the stepper

motor runs in the opposite direction to that expected, reverse the wiring to Aux 5 and Aux 6 channels.

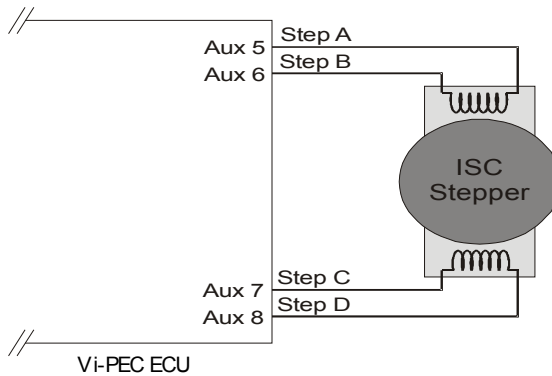

**Figure 8.15** - Four-terminal ISC Stepper Motor

### 8.3.4 – SIX TERMINAL ISC STEPPER MOTOR

**Note:** An ISC Stepper Motor must be wired to Aux 5, Aux 6, Aux 7 and Aux 8.

**When using an ISC Stepper, the ECU's power supply should be wired for ECU Hold Power as shown in Figure 6.2.** This will allow the ECU's Hold Power function to be taken advantage of. Using ECU Hold Power allows the ECU to reset the stepper motor after key off. This avoids extended cranking periods caused by resetting the stepper at key on.

Figure 8.16 shows a schematic of a six-terminal stepper motor. These are similar to a four-terminal Stepper Motor, but each coil has a centre-tap that must be connected to 12V. Like the four-terminal version, Aux 5 and 6 must be connected to the terminals for one coil, while Aux 7 and 8 must be connected to the terminals for the other coil. If it is found that the stepper motor runs in the opposite direction to that expected, reverse the wiring to Aux 5 and Aux 6 channels.

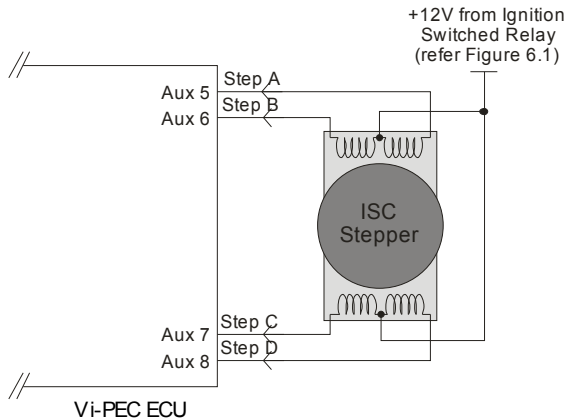

**Figure 8.16 - Six-terminal ISC Stepper Motor**

## 8.4 – TACHOMETER

An auxiliary output configured as 'Tacho' produces a 0-12V pulse train to drive a low-level tachometer. There will be one output pulse for each time a cylinder reaches TDC. Connect an Auxiliary Output directly to a low-level tachometer.

VX ECU's will NOT drive a high-level tachometer. High-level tachometers must be triggered by a coil's negative terminal. Using a high-level tachometer on a multi-coil engine presents some problems, as each coil is not firing as often as a distributor engine's coil would. In this case the preferred solution is to modify the high-level tachometer to accept a low-level signal.

## 8.5 – AUXILIARY OUTPUTS

VX ECU's have eight main auxiliary outputs. Unused ignition and injection channels can also be used as auxiliary outputs. Auxiliary outputs are general-purpose outputs that may be used to perform a wide range of functions. However, the following

limitations apply:

- A Three Terminal ISC Solenoid must be wired to Aux 1 and Aux 2.
- An ISC Stepper Motor must be wired to Aux 5, Aux 6, Aux 7 and Aux 8.
- Aux 5 to 8 and Ignition 1 to 4 when used as Aux channels can not be Pulse Width Modulated (PWM) above 300Hz.
- VVT Solenoids must be wired to Aux channels 1 to 4.
- An Electronic Throttle Control Motor must be wired to Aux 9 and Aux 10.

Auxiliary Outputs are used to supply a GROUND to actuate solenoids, relays, LEDs or lights. The amount of current flow is entirely dependant on the internal resistance of the device connected to a drive. The load must not draw more than 2 Amps of current. This means that a directly connected load should have a resistance exceeding  $7 \Omega$ . If the resistance is lower than this a relay should be used. **DO NOT** connect +12V directly to any auxiliary output.

On a typical two-terminal solenoid, the Auxiliary Output should be connected to one terminal to supply a ground, while the other terminal should be connected to an ignition switched (key ON) 12V source. A warning/shift light may also be wired the same way. This configuration is shown in Figure 8.17.

## WARNING

Figure 6.1 shows the correct way to wire a relay or solenoid to an Auxiliary output.

**Solenoids and relays wired to auxiliary outputs must take their switching coil power supply from a switched (through a relay) source. Do NOT use a +12V hot (direct from the battery) supply. Doing so may result in the ECU staying powered up when the key is switched off.**

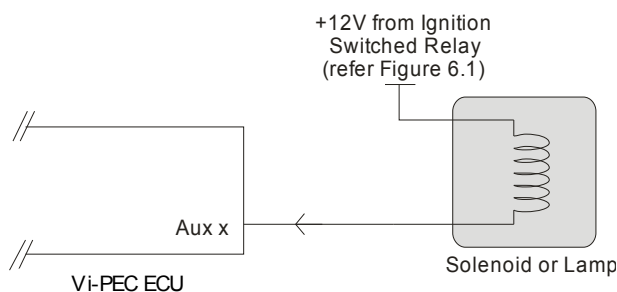

**Figure 8.17** - Wiring for two terminal solenoid or light

Some single terminal solenoids are grounded through the engine block (e.g. most Honda VTEC solenoids). Therefore 12V must be applied to the terminal on the solenoid to turn it on. In this case, a relay must be used, rather than connecting the auxiliary output directly to the solenoid. This configuration is shown in Figure 8.18.

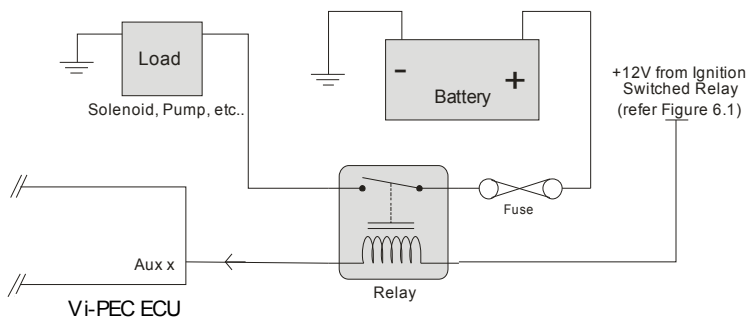

**Figure 8.18** - Wiring for single terminal solenoid using a relay

A solenoid/light driven off of a high power drive may be switched at a given RPM, MAP, engine temperature, injector duty cycle etc.

## 8.6 – ELECTRONIC BOOST CONTROL

Electronic boost control is achieved by modifying the pressure signal from the turbocharger compressor outlet to the wastegate actuator using a solenoid.

The minimum boost pressure that can be achieved occurs when the solenoid is de-energised. This pressure is entirely dependent on the wastegate actuator spring and wastegate sizing.

The maximum boost pressure that can be achieved occurs when the solenoid is always energised. This pressure is dependent on the turbocharger/engine combination. Typically this pressure exceeds that which can be safely tolerated by the engine.

By varying the on/off ratio (duty cycle) of the boost control solenoid, the ECU can adjust the boost pressure to anything between the minimum and maximum outlined above.

## 8.6.1 – RECOMMENDED BOOST CONTROL SOLENOID

The recommended boost control solenoid is shown in Figure 8.19 and is available from your Vi-PEC dealer. This solenoid may be used with both internal and external wastegates, although the plumbing for each type is very different. Although this solenoid has three ports, only two ports require connection.



**Figure 8.19** - Recommended Boost Control Solenoid

## 8.6.2 – INTEGRAL WASTEGATES

The solenoid should be connected as described below and shown in Figure 8.20.

- Port 1 is vented to the atmosphere (usually via the air filter)
- Port 2 is connected to the wastegate actuator canister
- Port 3 is connected to the turbocharger's compressor outlet

When the solenoid is de-energised, ports 2 and 3 are connected

and the compressor pressure is allowed to fill the actuator and open the wastegate. When the solenoid is energised Port 3 is blocked and Ports 1 and 3 are connected together. This allows the air pressure in the actuator to be bled off to atmosphere.

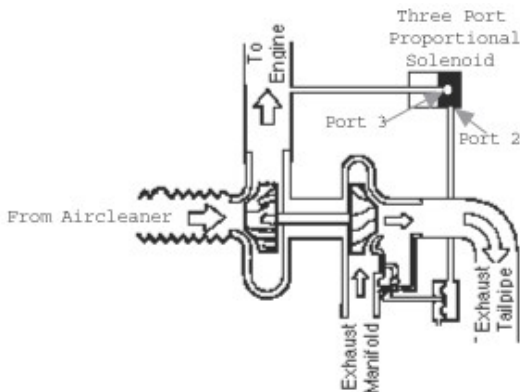

**Figure 8.20** - Plumbing of three-port solenoid to Internal Wastegate

### 8.6.3 – EXTERNAL WASTEGATES

In some applications, a factory-fitted integral wastegate in its fully open position may be unable to bypass a sufficient amount of exhaust gas to maintain the desired boost pressure. This condition is typically recognised when boost pressure rises uncontrollably at high engine speeds. In this case a larger diameter wastegate is required. Typically fitting an external wastegate is the easiest solution.

While both types of wastegates perform the same function, external wastegates have some important differences when compared to integral wastegates. Typical external wastegates actuators pull to open the wastegate rather than pushing it. Therefore, pressure must be applied to the bottom side of the diaphragm to open an external wastegate.

The preferred option is to use a second line from the compressor outlet to the topside of the diaphragm. The boost control solenoid is then plumbed into this line. The solenoid should be connected as described below and shown in Figure 8.21.

- Port 1 is connected to the turbocharger's compressor outlet
- Port 2 is connected to the port on the wastegate ABOVE the diaphragm
- Port 3 is vented to the atmosphere (usually via the air filter)

The port on the wastegate BELOW the diaphragm is connected to the turbocharger's compressor outlet (along with Port 1 on the wastegate solenoid).

The boost level is increased when more pressure is applied above the diaphragm. When the solenoid is de-energised, port 1 is blocked so that the top of the wastegate is at atmospheric pressure. When the solenoid is energised ports 1 and 2 are connected and the compressor pressure is allowed to fill the topside of the wastegate (above the diaphragm).

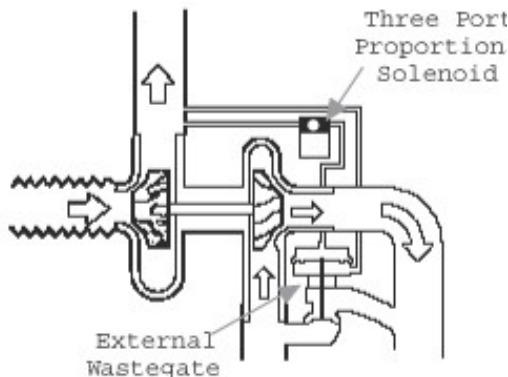

**Figure 8.21** - Plumbing of three-port solenoid to External Wastegate

## 8.6.4 – WIRING AND MOUNTING OF BCS

A solenoid's operation can be checked by blowing through its ports with the solenoid both energised and de-energised.

To keep the length of the pressure lines as short as possible, the solenoid should be mounted close to the wastegate. However, the solenoid must not be placed too close to hot exhaust manifolds and turbine housings as eventual failure may result.

Remember that an Auxiliary Output connects directly to one terminal on the solenoid to provide an EARTH. The other terminal on the solenoid must be connected to an ignition switched (key ON) 12V source. The orientation does not matter. Wiring is shown in Figure 8.22.

There are several options for referencing the boost targets. Boost may be setup at a fixed level, high/low boost on a switch (using a digital input), boost by gear (using a vehicle speed sensor connected to a digital input), TPS referenced and RPM referenced. Keep in mind that the inputs required for the chosen boost control mode must also be connected.

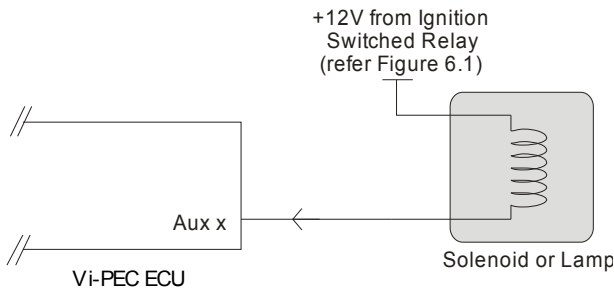

**Figure 8.22 - Wiring of control solenoid**

## 8.7 – SWITCHING THROUGH A RELAY

To switch any large load through a relay, the wiring shown in Figure 8.23 should be used. Examples of such loads include fuel pumps, engine coolant fans and air conditioning compressor clutches.

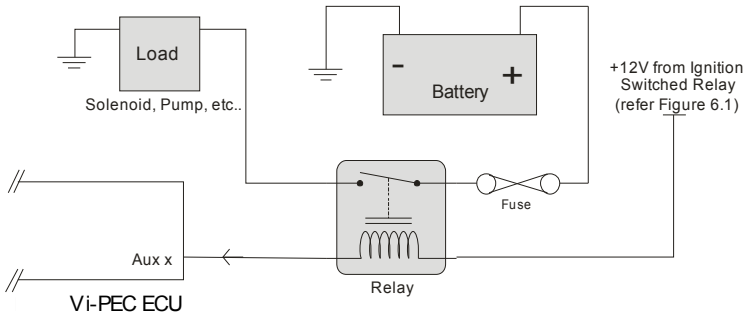

**Figure 8.23** - Wiring for large loads switched off a relay

### 8.7.1 – FUEL PUMP RELAY

When the fuel pump is switched using an Auxiliary Output the fuel pump will be activated for a few seconds after the key is turned ON. This will prime the fuel system and build up fuel pressure. When the engine is cranked the fuel pump will begin running continuously. When the engine is stopped the fuel pump will turn off regardless of the key position. This ensures that in the event of a crash the fuel pump will not run continuously. For this reason, it is highly recommended that the fuel pump relay be controlled via an Auxiliary Output and not using a dash mounted switch. As explained earlier, always use the auxiliary output to switch a relay and not the pump itself.

Fuel pump and fuel pump relay wiring is shown in Figure 6.1.

## 8.7.2 - ENGINE COOLANT FAN RELAY

This function activates the radiator coolant fan when the set temperature is exceeded. As explained earlier, always use the auxiliary output to switch a relay and not the fan motor itself. Wire according to Figure 8.23.

## 8.7.3 – AIR CONDITIONING CLUTCH

An auxiliary output may be used to switch the relay for the air conditioning fan or clutch when the air conditioning request signal is activated (via a digital input). This allows the ECU to perform idle speed and fuelling correction before latching the relay and loading the engine. As explained earlier, always use the auxiliary output to switch a relay and not the load itself. Wire according to Figure 8.23.

## 8.7.4 – INTERCOOLER WATER SPRAY

This is used to switch a pump to spray water mist over an air/air intercooler. As explained earlier, always use the auxiliary output to switch a relay and not the pump itself. Wire according to Figure 8.23.

## 8.8 – WATER OR NITROUS OXIDE INJECTION

An auxiliary output may be used to provide control of water or nitrous oxide injection. In either of these cases the auxiliary output may be connected directly to a solenoid placed before the injection nozzle. The auxiliary output can then control when the water or NO<sub>2</sub> is injected based on the conditions set by the user. Note that a the Dual Ignition Table function can be used to provide ignition retarded for NO<sub>2</sub>. The second ignition table can be configured to be activated when the NO<sub>2</sub> is activated.

## 8.9 – SWITCHING AN LED

Auxiliary outputs may be connected to a high intensity LED to provide a shift, or warning light. However, a 1k  $\Omega$  (1000  $\Omega$ ) current limiting resistor is required to be placed in series with the LED. Failure to install the resistor will result in permanent failure of the LED. A bulb may also be used instead of an LED (and it does not require a resistor). Figure 8.24 shows how to connect an LED.

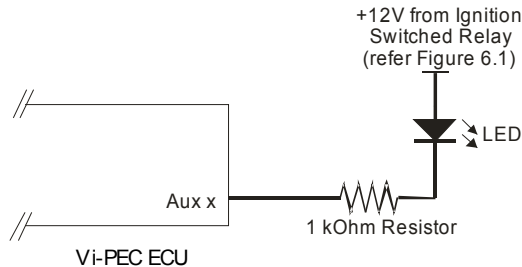

**Figure 8.24** - Connection of an LED to an auxiliary output

## 8.10 – EMISSIONS CONTROL SOLENOIDS

Various systems are used to reduce vehicle emissions such as carbon Purge cannisters and Exhaust Gas Recirculation (EGR). Typically a solenoid controls this process and may be activated by an auxiliary output. Wire according to Figure 8.22.

## 8.11 – VVT CONTROL SOLENOIDS

Continuously Variable Valve timing (CVVT, VVT, VVTi, AVCS) Cam Position solenoids can only be connected to Auxiliary Outputs 1 to 4.

It is recommended to ease configuration that cam position control solenoids are wired to the same number Auxiliary Output channel as the corresponding cam position Digital Input (refer following

example).

Although not absolutely necessary, it is recommended to ease configuration that cam position signals are wired to the same number Digital Input channel as the corresponding solenoid control Auxiliary Output (refer following table).

For compatibility, the following use of Digital Inputs and Auxiliary outputs is recommended for VVT wiring. Note that in practice any Digital Input/Auxiliary Output combination can be used.

Cam Shaft	Digital Input	Auxiliary Output
Inlet or Inlet LH	DI 1	Aux 1
Inlet RH	DI 2	Aux 2
Exhaust or Exhaust LH	DI 3	Aux 3
Exhaust RH	DI 4	Aux 4

Solenoids **MUST** be wired directly to an auxiliary output channel **DO NOT** wire continuously variable valve timing solenoids through a relay as high frequency switching is used.

Some factory systems use 12V switching to control VVT solenoids. These solenoids must be rewired to be ground switching.

Wire as pre Figure 8.22.

## 8.12 – ELECTRONIC THROTTLE CONTROL

At the time of writing this manual VX ECU's are equipped with tested Electronic Throttle Control hardware but not released with this feature enabled.

This section of the manual will be updated once the feature is released.

# 9 – PC TUNING

---

VX ECU's require PC/laptop tuning using the Vi-PEC Tuning Software application running on a Windows based computer. Vi-PEC Tuning Software may be downloaded from [www.Vi-PEC.com](http://www.Vi-PEC.com). Note that when new versions of Vi-PEC Tuning Software are released they are posted on the website and may be downloaded at no cost. Also note that VX ECU's must be used with the correct version of Vi-PEC Tuning Software.

## **WARNING !!!**

**The VX ECU has on board USB. BEFORE connecting the ECU to your laptop, the USB drivers must be installed. Failure to install the drivers on your laptop first may result in windows assigning incorrect drivers. These drivers will not work with the VX ECU and are difficult to uninstall.**

## 9.1 – INSTALLING USB DRIVERS

Before connecting the ECU to your laptop or PC, the ECU USB drivers must be installed. These drivers are installed as part of Vi-PEC Tuning Software installation as Vi-PEC Tuning Software described in the following section. Should internet download not be practical, a copy of the drivers on CD can be obtained from your nearest Vi-PEC Dealer. If the latest version of Vi-PEC Tuning Software has been installed then skip to Section 9.3.

## 9.2 – INSTALLING VI-PEC TUNING SOFTWARE

Due to the frequent updates Vi-PEC Tuning Software is no longer

shipped with each ECU. You will be required to download the latest version of Vi-PEC Tuning Software from website:

[www.Vi-PEC.com](http://www.Vi-PEC.com)

Should access to an Internet connection be impractical, the latest version of Vi-PEC Tuning Software can be requested from your nearest Vi-PEC dealer on CD.

### 9.2.1 – INSTALLING FROM THE WEB

1. Go to the above website and navigate to the downloads and software updates section.
2. Download the latest version of Vi-PEC Tuning Software. When prompted to run or save the file, select save. It is recommended to save this file on the desktop.
3. Double click the saved file and follow on screen instructions.
4. When prompted to install USB drivers, select yes. This may take some time.
5. When installed, open Vi-PEC Tuning Software by double clicking on the icon that has been placed on the desktop.

### 9.2.2 – INSTALLING FROM A CD

1. Insert the Vi-PEC Tuning Software disk into you computer's CD ROM.
2. Open 'My Computer'
3. Double click your CD rom drive.
4. Double click the file labelled Vi-PEC Tuning SoftwareSetup.exe (or similar name).
5. Follow the on screen instructions.
6. When prompted to install USB drivers, select yes. This may take some time.
7. When installed, open Vi-PEC Tuning Software by double

clicking on the icon that has been placed on the desktop.

## 9.3 – COMMUNICATING WITH YOUR ECU

After Vi-PEC Tuning Software installation, you will be able to connect to the VX ECU to the laptop to perform setup and tuning work.

1. Connect the ECU to your laptop using a Vi-PEC VX ECU USB Cable. If not supplied with the ECU, these can be purchased from a Vi-PEC dealer. No other adapter or cabling is required. Connect the cable to the connector labelled USB.
2. If this is the first time you have connect a VX USB ECU to you laptop follow the driver installation instructions that appear. When prompted if you wan to install drivers select 'Continue Anyway'.
3. Start Vi-PEC Tuning Software by double clicking on the Vi-PEC Tuning Software icon on the windows desktop.
4. Switch the key to the ON position. This will provide power to the ECU.
5. In Vi-PEC Tuning Software, under the 'Options' menu, select 'Connection'. The connection options dialogue will open. Select the correct Com Port number from the drop down list or select auto for automatic com port detection.
6. Vi-PEC Tuning Software offers both mouse and keyboard control. To establish a connection between the PC and ECU using the mouse, click the 'L' icon located near the top centre of the Vi-PEC Tuning Software screen. Alternatively, using the keyboard, press and hold the Ctrl, Shift and L keys. The same process can be used to disconnect. If a successful connection is established, Vi-PEC Tuning Software will download settings from the ECU, otherwise you will be warned that an error has occurred.

7. Make sure the connection shows “ONLINE” in the top right corner of Vi-PEC Tuning Software. The logo should also be spinning in the top right corner.
8. To permanently STORE any changes made to the ECU click on the 'S' icon near the top centre of the screen or press F4. If this is not done before turning the ECU's power off all changes made will be lost.

# 10 – FIRST TIME SETUP

---

This section of the manual details a generic procedure for first time setup of the VX ECU. These procedures also provide a good means of becoming familiar with both the VX ECU and Vi-PEC Tuning Software tuning software. It is recommended that these procedures are followed for every setup, no matter how experienced you are!

## 10.1 – PRE-START SETUP

To avoid potential engine damage and wasted time, the adjustments presented in the following sections **must** be made before attempting to start the engine.

**For further help on any of the settings discussed below, consult the online Help in Vi-PEC Tuning Software. Online help can be invoked by pressing F1, or right clicking any item and selecting ‘What’s this?’.**

### 10.1.1 – PRE-SETUP CHECKS

Before attempting to configure the ECU, ensure the following tasks have been completed:

1. Ensure the ECU and all associated components are connected and correctly wired/installed.
2. Fully charge the vehicle’s battery, as the engine will be required to be cranked during the setup procedure.
3. Check all oil and water levels are correct.

### 10.1.2 – CONNECTING TO Vi-PEC Tuning Software

As detailed in Section 9.3, use the following procedure to

establish a connection between your Vi-PEC ECU and Vi-PEC Tuning Software tuning software.

1. Make sure your laptop battery is fully charged or plugged in to mains power.
2. Connect the ECU to your laptop and connect to Vi-PEC Tuning Software as described in Section 9.3 of this manual.

## 10.2 – INITIAL CONFIGURATION

After all checks described in Sections 10.1.1 to 10.1.2 have been performed, the ECU is ready to be configured for a particular application. The following setup procedure should be used on all installations as a minimum:

### 10.2.1 – CONFIGURATION AND FUELING SETUP

If the ECU is to be used to control fuel injection, all of the following steps must be performed. If the ECU will not be controlling fuel injection, then only steps 1 and 2 are required.

1. If you have a .pcl file containing a base configuration, this is the time to load it into the ECU. To do this, select 'Open' from the 'File' menu. Select the required .pcl file and then select 'Ok'. When prompted if you want to load the file into the ECU, select 'Yes'.
2. Click on the 'Configuration' heading in the tuning function tree (top left of Vi-PEC Tuning Software screen):
  - a. Select the correct engine type
  - b. Select the correct number of cylinders/rotors.
  - c. Enter the engines firing order.
3. Click on the 'Fuel' heading, then 'Fuel Setup':
  - a. Select the desired Injection Mode (eg Sequential

- or Group).
  - b. Select Injector Control method (eg Saturated or Peak and Hold) (V88 ECU only). Also set the correct injector peak and hold currents.
  - c. Set main fuel table load axis control parameter (eg MAP, MGP or TPS).
4. Click on 'Accel Enrichment':
    - a. Turn Accel Mode OFF for first time setups.
  5. Click on 'IAT Fuel Correction':
    - a. If air temperature correction is to be used and an air temperature sensor is fitted, select the required 'IAT Mode' (eg 2D Table or 3D Table). Note that the default 2D Table is recommended for the majority of applications.
    - b. Turn OFF air temp correction (under 'IAT Mode') if air temperature correction is not going to be used
  6. Click on 'Injector Deadtime':
    - a. Select the appropriate Injector Type. If the required injector type is not listed, select the closest type available. The injector dead time table will be set up later when the engine is running.
  7. Click on 'Fuel Temp Correction':
    - a. Set 'Fuel Temp Mode' to OFF if not required.
    - b. If fuel temperature correction is required and a fuel temperature sensor has been fitted, set 'Fuel Temp Mode' to the desired type.
  8. Click on 'Overrun Fuel Cut':
    - a. Set 'Fuel cut Mode' to OFF.
  9. Click on 'Fuel Advanced', then 'Dual Fuel Table':
    - a. Set 'Dual Table Mode' to OFF.
  10. Click on '4D Fuel Table':
    - a. Set 'Fuel Overlay Mode' to OFF.
  11. Click on 'Injector Test';

- a. Turn each injection channel on one by one and check that the correct cylinders injector clicks. Fix any problems now if the injectors do not operate.
12. Perform a Store to permanently save changes to the ECU by pressing F4.

## 10.2.2 – IGNITION SETUP

If the ECU is to be used to control ignition, all of the following steps must be performed. If the ECU will not be controlling ignition, then only step 12 is required.

13. Click on 'Ignition' then 'Ignition Setup':
  - a. Select the correct type of 'Ignition Mode' for the application. Set to 'OFF' if ignition is not controlled by the ECU.
  - b. Set 'Maximum Advance' to a suitable value.
  - c. Enter appropriate values for coil dwell time in the 'Ignition Dwell Time' table.
14. Click on 'ECT Ign Trim':
  - a. Set 'Engine Temp Correction' to OFF (for now).
15. Click on 'IAT Ign Trim':
  - a. Set 'Air Temp Correction' to OFF (for now).
16. Click on 'Ignition Advanced' then 'Individual Cyl Ign Trim':
  - a. Set 'Indiv Ign Mode' to OFF (for now).
17. Click on 'Dual Ign Table':
  - a. Set 'Dual Table Mode' to OFF (for now).
18. Click on '4D Ign Table':
  - a. Set '4D Ign Mode' to OFF (for now).
19. Click on 'Ignition Test':
  - a. Turn each ignition channels test function on one by one.
  - b. Check for a quiet clicking sound from each coil

or alternately connect a spark gap and check for spark on the correct cylinders.

- c. Correct any problems before continuing.
20. Perform a Store to permanently save changes to the ECU by pressing F4.

### 10.2.3 – LIMITS SETUP

At this stage it is not necessary to precisely set all limits. However, it is essential to ensure they are set to values that will not interfere with tuning procedures. It is advisable to err on the conservative side when setting limit values.

21. Click on 'Limits' then 'RPM Limit':
  - a. Select the desired 'RPM Limit Mode'
  - b. Enter the required RPM limiting value for each engine temperature in the 'RPM Limit Table'.
22. Click on 'MAP Limit':
  - a. Select the desired 'MAP Limit Mode'
  - b. Enter the required MAP limiting value for each engine temperature in the 'MAP Limit Table'.
23. Click on 'Vehicle Speed Limit'
  - a. Set the 'Vehicle Speed Limit' to a high enough value to ensure it is not invoked during tuning. Note that this limit will only be effective if a vehicle speed sensor is correctly wired and configured.
24. Perform a Store to permanently save changes to the ECU by pressing F4.

### 10.2.4 – AUXILIARY OUTPUT SETUP

This section configures the ECU's Auxiliary Output drivers for the devices they have been wired to. Preparing a configuration table as shown in Section 2.7 of this manual will greatly simplify

setup of Auxiliary Outputs. Note that one auxiliary channel should always be wired and configured for the fuel pump relay drive.

25. Click on 'Auxiliary Outputs' then select the first Auxiliary Output that requires configuration:
  - a. Select the required 'Function' for the Auxiliary Output channel.
  - b. Configure the channel as required. Refer to Vi-PEC Tuning Software's online help for more information on adjustments.
26. Configure each additional Auxiliary Output channel. Ensure unused channels have their 'Function' set to 'Not Selected'. Note that the 'Test On' and 'Test PWM' functions can be used to test wiring of auxiliary output devices.
27. Configure any Ignition and Injection channels used for auxiliary output functions in the same manner.
28. Perform a Store to permanently save changes to the ECU by pressing F4.

## 10.2.5 – DIGITAL INPUT SETUP

This section configures the ECU's Digital Input channels for the devices they have been wired to. Preparing a configuration table as shown in Section 2.7 will greatly simplify setup of Digital Inputs.

29. Click on 'Digital Inputs' then select the first Digital Input that requires configuration:
  - a. Select the required 'Function' for the Digital Input channel.
  - b. Configure the channel as required. Refer to Vi-PEC Tuning Software's online help for more information on adjustments.

- c. Confirm the operation of the Digital Input by opening the Digital Inputs tab of the runtime values (lower area of Vi-PEC Tuning Software screen).
30. Configure each additional Digital Input channel. Ensure unused channels have their 'Function' set to 'OFF'.
31. Perform a Store to permanently save changes to the ECU by pressing F4.

## 10.2.6 – ANALOG INPUT SETUP

This section configures the ECU's Analogue Input channels for the devices they have been wired to. Preparing a configuration table as shown in Section 2.7 will greatly simplify setup of Analogue Inputs. Essential inputs are configured in this section. All steps must be performed on all applications.

32. Click on 'Analogue Channel'.
33. Select the Analog Channel that is wired to the MAP sensor.
  - a. Set the function to 'MAP Sensor'.
  - b. Select the correct "MAP Sensor Type".
  - c. Ensure the MAP runtime value reads reasonably close to the barometric pressure reading (BAP).
  - d. Perform a MAP Sensor Calibration. Do this by selecting 'MAP Sensor Calibration' from the Tools menu and following on screen instructions.
34. Select the Analog Channel that is wired to the TPS sensor:
  - a. Set the function to TPS (main).
  - b. Perform a TPS Calibration. Do this by selecting 'TPS Calibration' from the Tools menu and following on screen instructions.

35. Set up all other connected Analog Volt channels as required.
36. Set unused channels to OFF.
37. Click on the An Temp channel wired to the engine coolant temperature (ECT sensor).
  - a. Set the channels function to 'ECT'.
  - b. Select 'Temp Sensor Type'. If a custom type sensor is to be used then the resistance vs. temperature values should be entered now.
  - c. Confirm correct reading of the sensor by opening the Analog Inputs tab runtime values (lower area of Vi-PEC Tuning Software screen).
38. Repeat the previous step for all Analog Temperature channels.
39. Perform a Store to permanently save changes to the ECU by pressing F4.

## 10.2.7 – TRIGGER SETUP

Trigger setup requires entering information regarding the way in which engine speed and position is measured. Consult the Vi-PEC Tuning Software online help for further information on functions.

**WARNING: These are probably the most critical setup values. Do not attempt to start the engine unless you are 100% confident that these values are correct.**

If trigger information is unknown, consult your nearest Vi-PEC dealer for further assistance.

40. Click on 'Triggers' then 'Trigger Setup':
  - a. Configure triggers as required.
41. Click on 'Trigger1':
  - a. Select correct trigger type and setup completely.

42. Click on 'Trigger2':
  - a. Select correct trigger type and setup completely.
43. Perform a Store to permanently save changes to the ECU by pressing F4.

### 10.2.8 – ADDITIONAL SETUP

It is important that all features not required for initial tuning are either disabled or correctly setup. It is recommended that features be initially disabled to ensure they do not complicate tuning.

44. Click on 'Motorsport' then 'Antilag':
  - a. Set 'Antilag Mode' to OFF.
45. Click on 'Launch Control':
  - a. Set 'Launch Control Mode' to OFF..
46. Click on 'Flat Shifting':
  - a. Set 'Flat Shifting Mode' to OFF.
47. Click on 'Boost Control' (only visible if an Auxiliary Output is configured for a Boost Control Solenoid) then 'Boost Setup':
  - a. Configure Boost Control as described in the Vi-PEC Tuning Software online help.
48. Click on 'Dual Boost Maps':
  - a. Set 'Dual Boost Mode' to OFF.
49. Perform a Store to permanently save changes to the ECU by pressing F4.

## 10.3 – TRIGGER CALIBRATION

The following instructions assume that all pre-start setup instructions given in Sections 10.2 have been completed. Only after all pre-start checks have been made should an attempt be made to crank the engine. The following steps must be performed before an attempt is made to start the engine to ensure the ECU is calibrated to precisely measure engine

position.

1. Connect the ECU to Vi-PEC Tuning Software.
2. Select 'Fuel', then 'Fuel Setup':
  - a. Set 'Injection Mode' to OFF. This will prevent the engine from trying to start while the triggers are calibrated.
  - b. Perform a Store (press F4) to make sure fueling is not re-enabled if power to the ECU is lost.
3. Click on 'Triggers' then 'Calibrate Triggers'.
4. Perform the correct trigger calibration procedure as described in the Vi-PEC Tuning Software online help (Press F1).

Note that trigger calibration must be performed again once the engine is running. Due to the acceleration and deceleration of the crankshaft at low speeds, an inaccurate measurement of engine timing is usually made. Also it is often harder to see timing marks with a timing light at slow engine speeds. Trigger calibration should be checked again at between 2000-4000 RPM where engine speed is stable and a more consistent timing reading can be obtained.

## 10.4 – FIRST TIME STARTUP

After performing all setup instructions given in Sections 10.2 and 10.3, including trigger calibration, the engine is now ready to be started. The following procedure should be used for first time start-up:

1. Turn the ignition key OFF then ON. The fuel pump should prime momentarily upon power up.
2. Connect the ECU to Vi-PEC Tuning Software.
3. Click on each of the runtime value tabs (located about two thirds of the way down the screen) and check that all

values are as expected. Where possible operate sensors (eg TPS) to ensure correct readings are displayed. The following values should be checked:

- a. TPS – spans from 0 to 100% when throttle is pressed. If not, perform a TPS Calibration.
  - b. MAP – should read approx 101 kPa (at sea level) with the engine not running. If not, check the MAP Sensor Type setting and perform a MAP Calibration.
  - c. ECT – should read current engine temperature.
  - d. IAT – should read current intake air temperature.
  - e. Digital Inputs – Operate switches connected to any digital inputs while watching the runtime value to ensure they operate as expected.
4. Rectify any faults found in Step 3.
  5. Click on the 'Fuel' heading, then 'Fuel Setup':
    - a. Locate the 'Master' setting. This will need to be adjusted during or just after start-up.
  6. Crank the engine until it starts. Some throttle may be required for first time start-up due to imperfect tuning. If necessary adjust the Master setting to enrich/lean the engine (increase to enrich).
  7. If the engine fails to start after several attempts, do not crank it endlessly. Stop and determine the problem before continuing.
  8. Check the Trigger Error Counter (found under the Triggers runtime values tab). If this value increases during cranking/running then there is a trigger setup fault. It is not unusual for this number to count one or two on the first engine revolution.
  9. Once the engine starts, adjust the 'Master' setting to achieve best possible running.
  10. The engine should now be allowed to fully warm up. It may be necessary to readjust 'Master' several times to maintain smooth running. Don't forget to keep an eye on

- engine temperature.
11. Once the engine is warmed up and running well, perform another trigger calibration (known “as setting the base timing”).
  12. Perform a Store by pressing F4.

## 10.5 – ESSENTIAL TUNING ADJUSTMENTS

It is assumed that at this stage all setup procedures described in Sections 10.1 to 10.4 have been completed and the engine is running. The following steps detail correct setup procedures for some of the more critical ECU parameters (note that MAP Sensor Calibration should have already been completed by now):

### 10.5.1 – MAP SENSOR CALIBRATION

At key on and engine not running the Manifold Absolute Pressure (MAP) Sensor should always match the Barometric Absolute Pressure (BAP) Sensor. As well as providing altitude correction, the BAP sensor also allows the MAP sensor to be calibrated prior to tuning.

VX ECU's use an on-board barometric sensor that is calibrated prior to dispatch. This ensures that all Vi-PEC Tuning Software programs (PCL Files) give a consistent state of tune throughout the ECU range. This allows a PCL file to be transferred between VX based ECU's giving an equivalent state of tune providing all factors affecting VE are equal.

Without the ability to calibrate all the available types of MAP Sensors to the BAP Sensor there would be significant affects on the accuracy of the resulting tune, especially when tuning with Manifold Gauge Pressure (MGP) as a load index.

To calibrate the MAP sensor, select the 'MAP Sensor

Calibration' item in the Vi-PEC Tuning Software 'Options' menu and follow on screen instructions.

## 10.5.2 – INJECTOR VOLTAGE (DEAD TIME) CORRECTION

There is always a delay between the injector being energised and the injector actually opening. Likewise, there is a small delay between the injector being de-energised and the injector closing. The opening time is considerably longer than the closing time, however the overall result is that less fuel will flow for a given pulse width than would be expected with an 'ideal injector'. To compensate for this the injector pulse widths are increased to compensate for this 'dead-time'. The dead-time for a given injector is a function of the battery voltage, differential fuel pressure and the type of injector driver (saturated or peak and hold). A typical dead-time at 3 Bar differential fuel pressure and 14 volts is just under 1ms (ms = millisecond = 1 thousandth of a second).

In applications with a linear 1:1 fuel pressure regulator (ie not a rising rate regulator), the differential fuel pressure (difference between manifold pressure and fuel pressure) will be constant. Therefore the only variable that is changing will be the battery voltage (this changes with electrical load and sometimes engine speed). Without correction, the changes in dead time will cause the engine to run lean when the voltage drops. If the Injector Voltage Correction is properly setup then changes in the battery voltage will not affect the air/fuel ratio.

The injector dead-time table allows the dead- time for different battery voltages to be entered. The values represent the dead-time in milliseconds. These should increase with falling system voltage.

Injector dead time for a particular set of injectors can be

determined using a flow bench or on a running engine.

To determine the injector dead-time using a flow bench, the injectors need to be operated at the intended operating pressure (normally three bar) and at a constant duty cycle as well as a set voltage. Vary the supply voltage to the injector and measure minimum pulse width at which the injectors will flow for a particular voltage. This is the required dead-time for that injector at that tested voltage.

To determine injector dead time on a running engine, with the engine fully warmed and operating at stable air/fuel ratios (a very precise AFR meter is required – a narrowband O2 sensor will not suffice), electrical drain needs to be applied to the system; the preferred method is disconnecting the alternator main fuse. Battery load testers are also useful here too.

Watching the air fuel ratios change while the battery voltage drops, the dead-time table can be trimmed to maintain the same stable air/fuel ratio. Injector Dead-Time can be viewed as a row graph. A smooth curve needs to be maintained at all times.

NOTE: any change to the fuel pressure or injectors will require a recalibration of the injector dead-times.

### 10.5.3 – MASTER

Master should be set so that the numbers in the middle of the fuel table end up around a value of 50. This is to allow sufficient span of the numbers in the main fuel table.